



SUPER BRILLIANT

SUMMER ACTIVITY BOOK



*FOR
UPPER ELEMENTARY*
Featuring activities from MLC and PBS KIDS

On TV. Online. Statewide.
Visit MichiganLearning.org





Now AVAILABLE

All-day literacy programming

WEEKDAYS
5AM To 5PM

Visit michiganlearning.org or check local listings to find your station.



WELCOME TO YOUR SUMMER ACTIVITY BOOK!

Here's how to use this book to have a summer full of learning and fun.

1

Use Grade Levels

This book spans multiple grade levels—choose a few lessons each week and explore new ones as you go. Save the tougher challenges for later in the summer or even next year.

2

Go Week by Week

This book is designed to be used over eight weeks—try spreading the activities across a few days each week. Find a routine that works best for your students.

3

Watch Helpful Videos

Scan the QR codes throughout this book to watch videos with extra instructions and examples, or find them all online at michiganlearning.org/summer

For Those Rainy Days and Beyond.

Find Michigan Learning Channel on your TV, watch our 24/7 online livestream, or explore our on-demand library anytime. Visit michiganlearning.org/schedule to see what's on our broadcast channel, or tune in to our free livestream.

On TV, online, statewide—anytime you need us.

WEEKS AND THEMES

Each week of our summer program has a different theme. See what's in store below.

Week 1: Take Flight

From planes and kites to butterflies and birds, discover the fables and physics of things that fly.

Week 2: Under Water

Dive deep into oceans, rivers, and our own Great Lakes to discover what it takes to live beneath the waves.

Week 3: Heroes

Celebrate our nation's birthday and the people we call heroes, whether they are veterans, everyday helpers, or the kind who wear capes.

Week 4: Creatures

From the prehistoric to the present, learn about the fascinating features of creatures near and far.

Week 5: Engineering

Meet the people who design bridges, cars, and video games and learn how to think like an engineer.

Week 6: Great outdoors

Explore the world outside your door and the incredible parks and waters that belong to us all.

Week 7: When I Grow Up

All summer we'll learn about different careers—this week, think about all the exciting possibilities in your future!

Week 8: Shoot for the Stars

Look up at the night sky and into outer space and meet people who risked everything to follow their dreams.



The Michigan Learning Channel (MLC) is a statewide education service powered by all seven of Michigan's public television stations*—working together to ensure every learner, family, and educator can access high-quality resources, everywhere in the state. Through this unified public media partnership, MLC expands learning beyond the classroom with trusted materials, enrichment opportunities, and community engagement that meet people where they are.

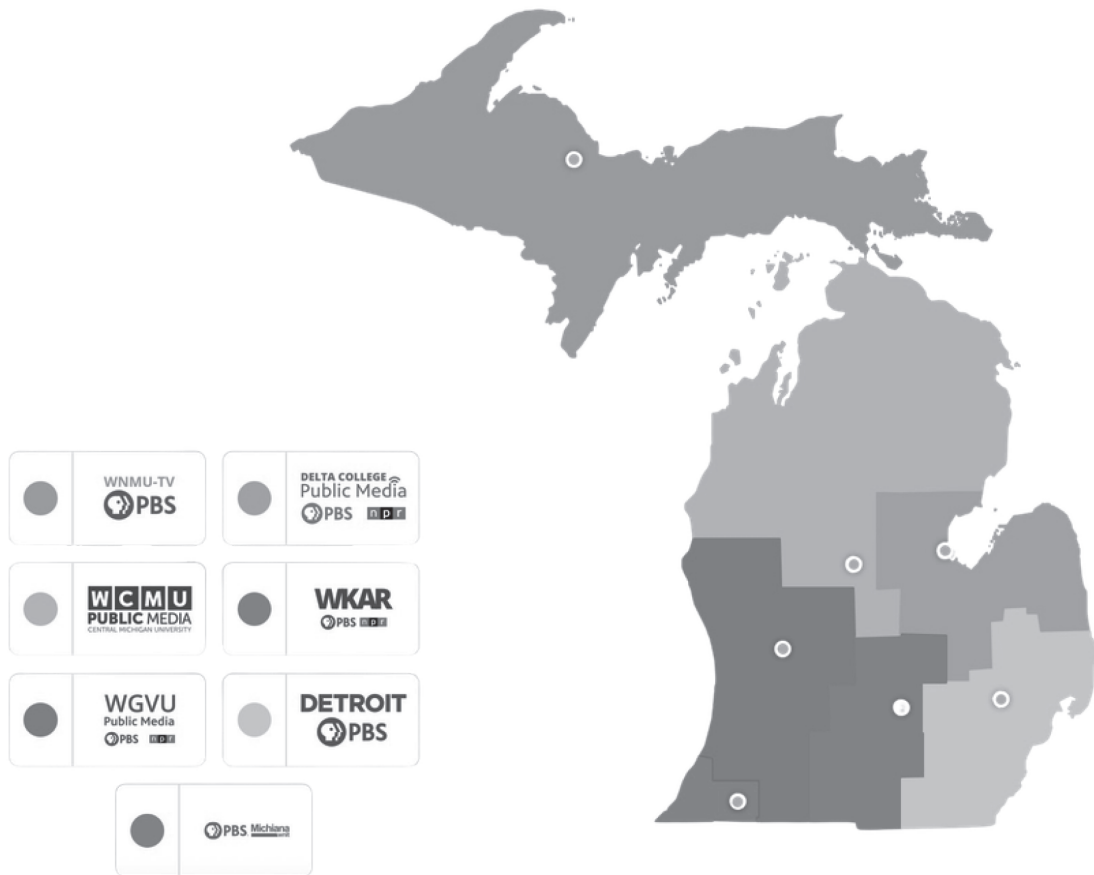

Note: WNIT is licensed in Indiana and serves parts of southwest Michigan via broadcast signal. Inclusion on this map reflects audience reach only.



Color Across Michigan!

Grab your crayons and travel across Michigan! Color the lakes, forests, cities, and wildlife you might find along the way. What colors make Michigan feel special to you?

WEEK 1: TAKE FLIGHT

Complete activities and play BINGO!

Scan the QR code or visit [Michiganlearning.org/summer](https://michiganlearning.org/summer) to see video lessons for this week's activities. Use the boxes below to check off activities as you complete them. See if you can get a BINGO!



Watch Read, Write, ROAR!	Complete Page 8-9 Activity	Find a windy spot outdoors	Make and fly a kite	Complete Page 15-17 Activity
Complete Page 12 Activity	Make wings from cardboard	Watch Wimee's World	Complete Page 10 Activity	Read outside under open sky
Draw a bird that you see	Fly a kite or paper glider	Free Space	Design your own flying machine	Sketch five different cloud types
Watch sunset colors change	Watch Math Might	Complete Page 11 Activity	Teach someone to fold airplanes	Complete Page 13 Activity
Complete Page 18 Activity	Create a windchime	Write a sky-themed poem	Watch PBS KIDS	Time a paper airplane flight

DIY Air Cannon



FUN FACT

Dolphins can create vortex rings to play with in the ocean by blowing air through their blowholes. The quick burst of air combined with the round shape of the blowhole creates a vortex ring of bubbles.

AIR PRESSURE

Air pressure, also known as atmospheric pressure, is the force exerted on a surface by the weight of air. Even though it is invisible to our eyes, the air surrounding us puts about 14.7 pounds per square inch of pressure on everything on the surface of Earth. That's a lot of pressure!

MATERIALS

- Plastic or styrofoam cups
- Scissors
- Balloon
- Various items to knock over

DIFFICULTY



Why do scientists love renewable energy so much?

*Answer on the next page

VISIT
DIYSCIENTIME.ORG
FOR MORE SCIENCE FUN!



Copyright Alabama Public Television and Mister C, LLC 2021

DIY Air Cannon

EXPERIMENT

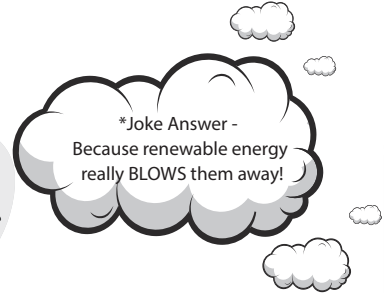

Step 1: Gather your materials.

Step 2: Cut the neck off of the balloon and keep the large part.

Step 3: Carefully cut a hole in the bottom of the cup about the size of a dime with your scissors.

Step 4: Attach the cut balloon to the mouth of the cup. Be sure to stretch it tightly and reinforce by wrapping a rubber band around the lip of the cup.

Step 5: Tap or gently pull back the balloon and let it go to force the air out of your cannon.

Step 6: Set up a target, such as hanging toilet paper, to test to see how far your air rings can reach.

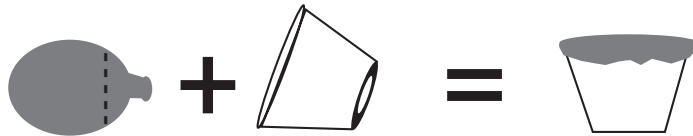

WHY IT WORKS

Although you can't see it, your cup is filled with air. When you apply a force to the air molecules by pulling back the balloon and letting it snapback, the air molecules are pushed towards the opening. This movement sets off a quick chain reaction of collisions with other air molecules and the sides of the cup. The only way for the air molecules to escape is through the opening at the bottom of the cup. The quick escape of these air molecules forms a stream of air that flows straight out of the cannon.

EXTEND YOUR LEARNING

- What might happen if you used a different sized cup? Could you cut a 2 liter bottle to make a larger cannon?
- Could you try another stretchy material to take the place of the balloon?
- Does it change the experiment if you make the hole a different shape? What if you place it in a different spot?
- Experiment with your air cannon to see what changes allow you to shoot air the furthest.
- Have a target competition with a friend.

WORKFORCE CONNECTION

A meteorologist studies interactions between temperature, humidity, air pressure, precipitation and vortices in the atmosphere. They develop an understanding of how vortices such as tornadoes, waterspouts and hurricanes form so they can predict the weather to keep people informed and safe. They also study and learn about the polar vortex and how it affects the weather during winter.



Rounding Whole Numbers

Directions: Round each number to the nearest **ten**.

1. $89 =$ _____

2. $154 =$ _____

3. $2,317 =$ _____

4. $3,591 =$ _____

5. $299 =$ _____

6. $312 =$ _____

Directions: Round each number to the nearest **hundred**.

1. $1,499 =$ _____

2. $634 =$ _____

3. $184 =$ _____

4. $3,451,981 =$ _____

5. $7,991 =$ _____

6. $900 =$ _____

Directions: Round each number to the nearest **thousand**.

1. $9,459 =$ _____

2. $17,999 =$ _____

3. $10,238,071 =$ _____

4. $892,099 =$ _____

5. $7,235 =$ _____

6. $19,961 =$ _____

DECODING WORDS: TRANSPORTATION



ACTIVITY GUIDE

SCAN TO
WATCH LESSON



EPISODE 105: GETTING FROM HERE TO THERE

Let's read about the Ambassador Bridge! Circle any words with the root word **-port-**. Remember, **-port-** means "to carry or bring." Then, use the key to discuss what those words mean!

The Ambassador Bridge

You may have heard of the Mackinac Bridge in Michigan, but do you know about the Ambassador Bridge? The Ambassador Bridge is an important bridge in Michigan that connects Detroit, Michigan, and Windsor, Ontario, in Canada! Many companies transport their goods across the bridge on large trucks.

Imports and exports sent over the bridge help people in both countries.

PREFIXES

ex-

out or away

im-

in or into

trans-

across or beyond

SUFFIXES

-ant

doing the action of
the verb

-s

more than one

Write a sentence about the Ambassador Bridge! Include two **-port-** words.



Paper Airplane

1. Fold paper in half the long way and reopen.

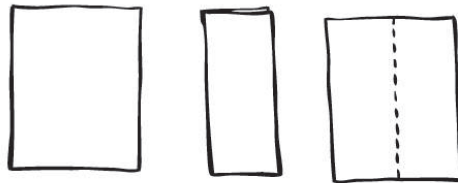

2. Fold the top two corners into the center spine of the paper.



3. Refold lengthwise and rotate the paper to lay on the table like this:



4. Fold the top left corner down to lay parallel to the bottom spine. Repeat this step on the other side.



5. Turn the paper over and repeat the last two steps. Your airplane should look like this!

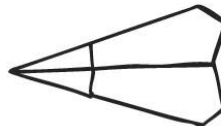

6. Now, try to fly it to the moon! How far can you make the airplane fly?

For more games and activities, visit pbskidsforparents.org

Produced by:
WIND DANCER
FILMS



Funded by:
Corporation
for Public
Broadcasting

The contents of this document were developed under a cooperative agreement (PR/Award No. U295A150003, CFDA No. 84.295A) from the U.S. Department of Education. However, these contents do not necessarily represent the policy of the Department of Education, and you should not assume endorsement by the Federal Government. © 2018 Jet Propulsion, LLC. Ready Jet Go! and the Ready Jet Go! logo are registered trademarks of Jet Propulsion, LLC. The PBS KIDS logo and PBS KIDS © PBS. Used with permission. Corporate Funding of Ready Jet Go! is brought to you by ABCmouse.com. Made available by the Corporation for Public Broadcasting, a private corporation funded by the American people.

Sponsored by:
ABCMouse.com™



IMPACT at HOME

Activity Cards

Cut out the cards. When you're feeling antsy, try following the directions for one of the exercises!

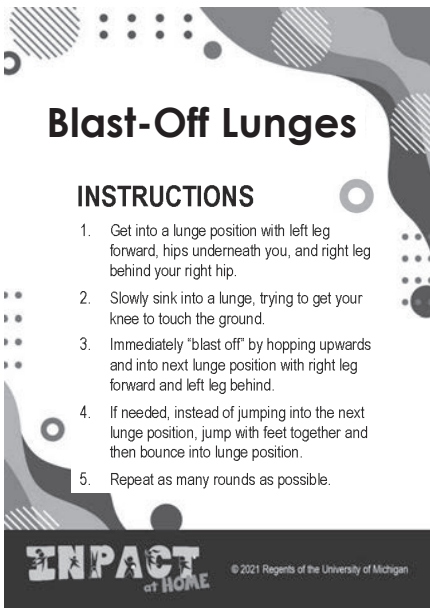

Blast-Off Lunges

INSTRUCTIONS

1. Get into a lunge position with left leg forward, hips underneath you, and right leg behind your right hip.
2. Slowly sink into a lunge, trying to get your knee to touch the ground.
3. Immediately "blast off" by hopping upwards and into next lunge position with right leg forward and left leg behind.
4. If needed, instead of jumping into the next lunge position, jump with feet together and then bounce into lunge position.
5. Repeat as many rounds as possible.

IMPACT at HOME © 2021 Regents of the University of Michigan



Side Leg Lifts

INSTRUCTIONS

1. Start by laying on your side with your legs stacked on top of each other.
2. Slowly raise your top leg up towards the sky and then back down.
3. Complete 10 repetitions and then switch legs.
4. Complete 3 sets per leg.
5. For added challenge, tape a bag of water to the top leg for some added weight!

IMPACT at HOME © 2021 Regents of the University of Michigan

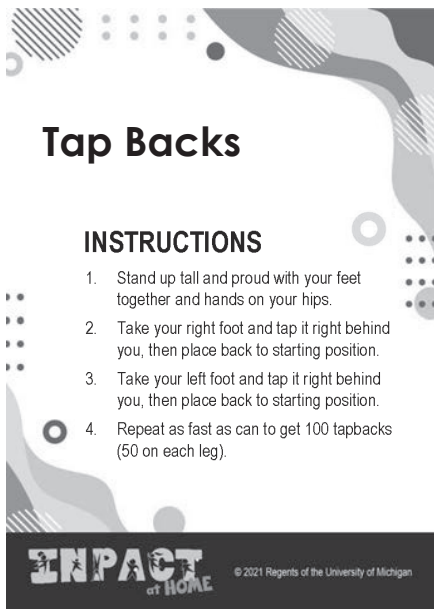

Tap Backs

INSTRUCTIONS

1. Stand up tall and proud with your feet together and hands on your hips.
2. Take your right foot and tap it right behind you, then place back to starting position.
3. Take your left foot and tap it right behind you, then place back to starting position.
4. Repeat as fast as can to get 100 tapbacks (50 on each leg).

IMPACT at HOME © 2021 Regents of the University of Michigan

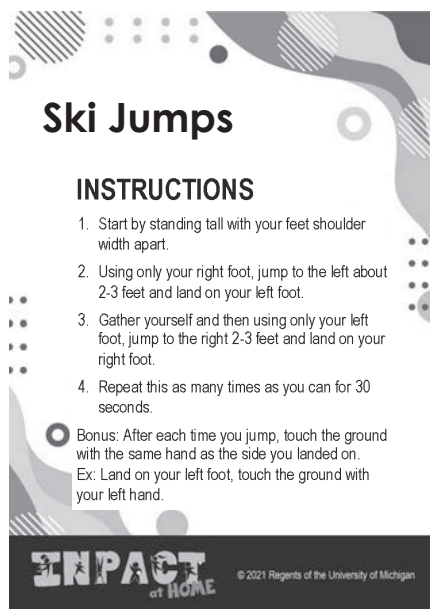

Ski Jumps

INSTRUCTIONS

1. Start by standing tall with your feet shoulder width apart.
2. Using only your right foot, jump to the left about 2-3 feet and land on your left foot.
3. Gather yourself and then using only your left foot, jump to the right 2-3 feet and land on your right foot.
4. Repeat this as many times as you can for 30 seconds.

 **Bonus:** After each time you jump, touch the ground with the same hand as the side you landed on.
Ex: Land on your left foot, touch the ground with your left hand.

IMPACT at HOME © 2021 Regents of the University of Michigan

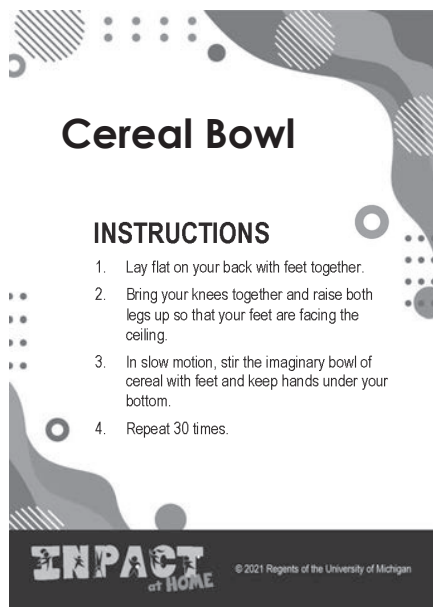

Cereal Bowl

INSTRUCTIONS

1. Lay flat on your back with feet together.
2. Bring your knees together and raise both legs up so that your feet are facing the ceiling.
3. In slow motion, stir the imaginary bowl of cereal with feet and keep hands under your bottom.
4. Repeat 30 times.

IMPACT at HOME © 2021 Regents of the University of Michigan

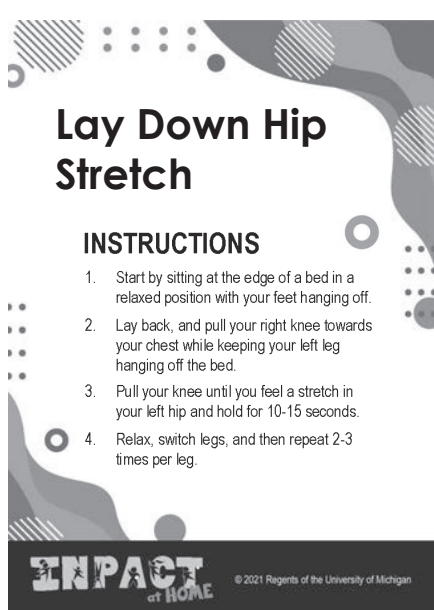

Lay Down Hip Stretch

INSTRUCTIONS

1. Start by sitting at the edge of a bed in a relaxed position with your feet hanging off.
2. Lay back, and pull your right knee towards your chest while keeping your left leg hanging off the bed.
3. Pull your knee until you feel a stretch in your left hip and hold for 10-15 seconds.
4. Relax, switch legs, and then repeat 2-3 times per leg.

IMPACT at HOME © 2021 Regents of the University of Michigan



Alligator Breath

INSTRUCTIONS

1. Stand with legs hip-width apart.
2. Spread arms out wide and inhale as you reach outward.
3. When you exhale, clap your hands together as many times as possible like baby alligator jaws.

IMPACT at HOME © 2021 Regents of the University of Michigan

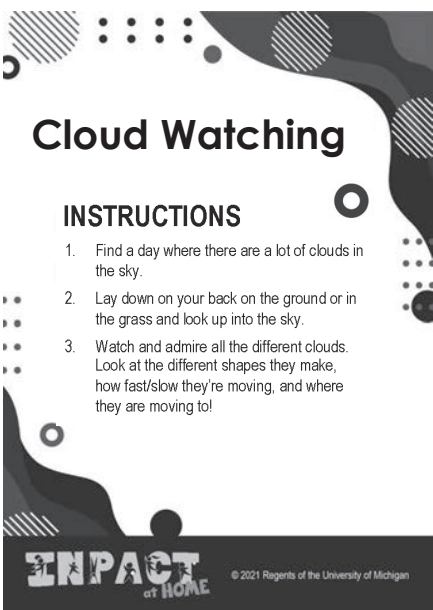

Cloud Watching

INSTRUCTIONS

1. Find a day where there are a lot of clouds in the sky.
2. Lay down on your back on the ground or in the grass and look up into the sky.
3. Watch and admire all the different clouds. Look at the different shapes they make, how fast/slow they're moving, and where they are moving to!

IMPACT at HOME © 2021 Regents of the University of Michigan

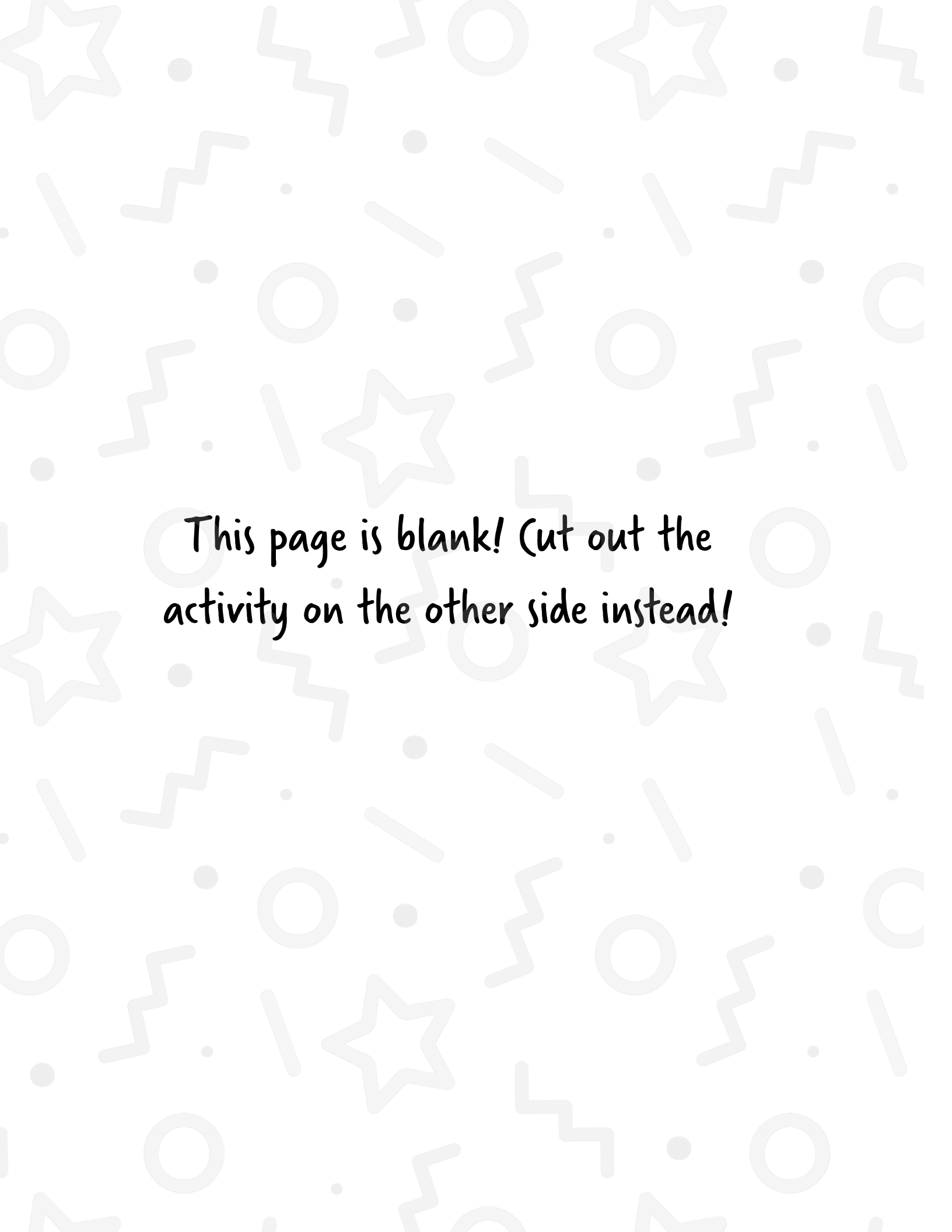

This page is blank! Cut out the activity on the other side instead!

DIY Inertia Walker



FUN FACT

Inertia combined with the gravitational pull from the sun, is what keeps our planet, Earth, orbiting the sun.

INERTIA

Newton's 1st law states an object at rest remains at rest, and an object in motion remains in motion unless acted on by an unbalanced force. In other words, we call the tendency of an object to do nothing or remain unchanged inertia.

We often experience inertia in our lives! Think about driving in a car and someone applies the brakes. Your body tries to keep moving forward, but the seatbelt holds you safely in place. Try looking at your chocolate milk while you are stirring it next time. Although you pull the spoon out, the milk keeps spinning and swirling in the cup.

MATERIALS

- Inertia walker printout
- Scissors
- Tape
- Marble
- Ramp

DIFFICULTY



Why do dentists love riding roller coasters?

**Answer on the next page*

VISIT
DIYSCIENTIME.ORG
FOR MORE SCIENCE FUN!



Copyright Alabama Public Television and Mister C, LLC 2021

DIY SCIENCE TIME

"Science is wherever YOU are!"



*Joke Answer -
They know how to
BRACE themselves!

DIY Inertia Walker

EXPERIMENT

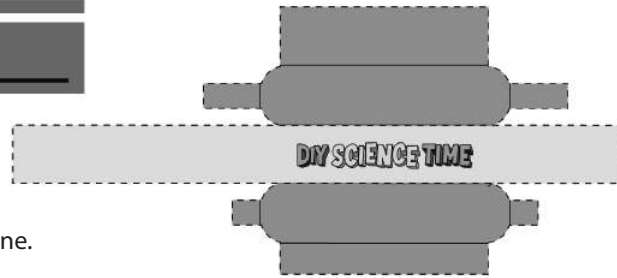

Step 1: Print and cut out the walker on the dashed line.

Step 2: Fold and crease the tabs on the solid lines.

Step 3: Tape the walker together where the tabs overlap. Place a marble inside the walker before taping closed.

Step 4: Build a ramp using books and a long flat surface such as a wood board or long box.

Step 5: Place your walker at the top of the ramp and release it!

WHY IT WORKS

Objects in motion want to stay in motion, and the marble inside the walker wants to roll down the ramp. The marble has enough inertia to push and force the rounded end of the walker down the ramp. Without that extra force from the marble, the walker would not be able to overcome the friction between its long side and the ramp's surface. This allows the walker to tumble and turn all the way down the ramp!

EXTEND YOUR LEARNING

- Could you design your own walker using household materials available to you?
- What happens if you use a larger or smaller marble? Can a smaller marble keep the walker moving?
- What other types of ramps could you test your walker on? Would it work on a slide at the park?
- Could you create a differently-shaped three dimensional object to be a walker? Would a cube work?

WORKFORCE CONNECTION

Biomedical engineers called kinesiologists are scientists who study how people move. Kinesiologists can help athletes improve how they perform in their sports by showing them how their motions can enhance their physical fitness and reduce chances for injuries. They must understand motion and forces, like inertia and gravity, and how they impact athletes' bodies.

Copyright Alabama Public Television and Mister C, LLC 2021

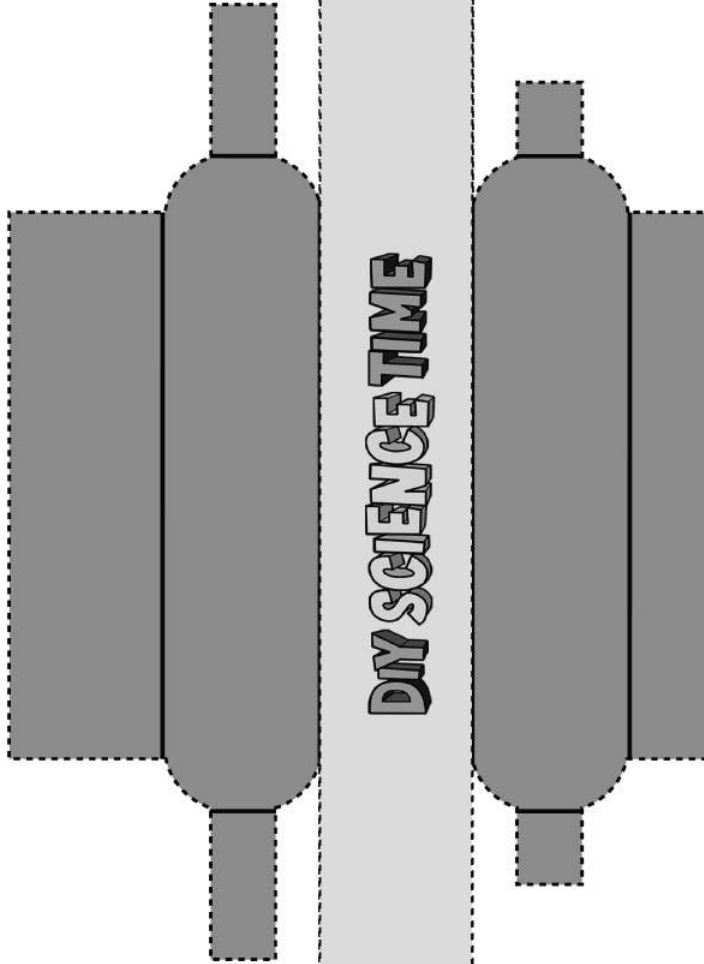

Directions:

Step 1: Cut out the walker on the dashed line.

Step 2: Fold and crease the tabs on the solid lines. Place a marble inside the walker before taping it shut.

Step 3: Build a ramp using books and a long flat surface such as a wood board or long box.

Step 4: Place your walker at the top of the ramp and release it!

Fold along solid lines. ✂ Cut along dashed lines.



ALABAMA PUBLIC TELEVISION

Copyright: Alabama Public Television and Mister C, LLC 2021



Nothing to see here! Cut out the activity on the other side instead!

Pendulum Art



1. Scan the QR code on this sheet to watch the video and follow along with Mr. C.



helps you

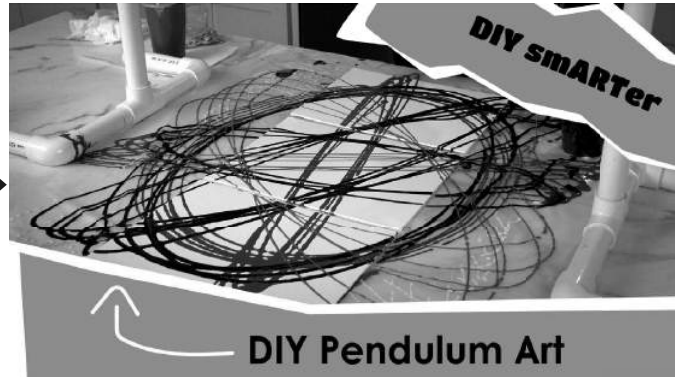

2. You'll need:

- a. This printout
- b. String
- c. Squeeze bottle or plastic cup for your bob
- d. Scissors
- e. Rubber bands and paperclips
- f. Paint
- g. Paper or canvas for painting

Discussion Questions:

What might happen if you use a longer or shorter string? How does the period of the pendulum impact your art?

What might happen if you give the condiment bottle a harder or softer push?

Does the type of paint impact the flow or pattern?

Fun Fact:

Pendulum clocks lose time when it is hot because the heat causes the metal to expand lengthening the rod. This causes the period to increase affecting the ability to keep time.

WEEK 2: UNDER WATER

Complete activities and play BINGO!



Scan the QR code or visit [Michiganlearning.org/summer](https://michiganlearning.org/summer) to see video lessons for this week's activities. Use the boxes below to check off activities as you complete them. See if you can get a BINGO!

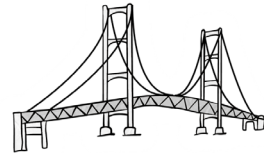

Watch Read, Write, ROAR!	Sketch a lake habitat	Pick up litter near water	Skip a rock across the water	Test what objects sink
Complete Page 25 Activity	Complete Page 21 Activity	Watch Wimee's World	Build a tiny dam when it rains	Look for insects near water
Test what objects float	Identify three water birds	Free Space	Complete Page 22-23 Activity	Make bubble art with soap and water
Complete Page 24 Activity	Watch Math Mights	Build a mini floating boat	Read by the water	Write a short lake adventure
Build a foil boat — how many coins hold?	Create a mini lake in a jar	Rest quietly for 15 minutes outside	Watch PBS KIDS	Complete Page 26-27 Activity

DIY Can Crush



FUN FACT

Implode is the opposite of explode. When something implodes, it quickly collapses inward. Buildings are often imploded when they need to be demolished so that the destruction doesn't hurt nearby buildings or surroundings.

MATERIALS

- An adult helper
- Stovetop or burner
- Empty soda cans
- Large bowl of ice
- Water
- Tongs

DIFFICULTY



AIR PRESSURE

Air is EVERYWHERE! Air is the invisible gaseous substance that surrounds all of the Earth. There are five layers to Earth's atmosphere and gravity is pulling down on the air molecules in each layer. That pulling is what creates atmospheric pressure.

VISIT
DIYSCIENTIME.ORG
FOR MORE SCIENCE FUN!



What do you call the study of soft drinks?

*Answer on the next page

Copyright Alabama Public Television and Mister C, LLC 2021

DIY SCIENCE TIME

"Science is wherever
YOU are!"



*Joke Answer -
Fizz-ics!

DIY Can Crush



EXPERIMENT

Step 1: Gather materials.

Step 2: Fill a large bowl halfway with ice water.

Step 3: Add an 1/8 cup of water to the bottom of the can (just enough to cover the bottom).

Step 4: Place the can on the center of the burner. Once it's stable, turn the burner on high until it has steamed for at least 1 minute.

Step 5: Use your tongs to grasp the can so that you can safely flip the can over and into the ice water.

Step 6: Quickly flip the can over and place into the ice water so that the opening is submerged. Be careful to not splash hot water as you flip the can.

WHY IT WORKS

As the water in the can heats up, it changes from a liquid to a gas, making water vapor. The water vapor pushes the air out of the can. Once the can is upside down in the ice water, the hot water vapor is trapped inside and quickly cools after it's submerged in the ice water. The water vapor condenses leaving empty space in the can. The air outside of the can has pressure, exerting 14.7 pounds of pressure per square inch on the can! Without the air inside of the can, the air pressure is unequal and the outside air easily crushes the can.

EXTEND YOUR LEARNING

- What would happen if you used room temperature water instead of ice water?
- What happens if you use a different sized can?
- What happens if you don't heat your can up before turning over into the ice water?
- Does the size of your ice impact the experiment?

WORKFORCE CONNECTION

Aerospace engineers have to understand how pressure and a lack of pressure (vacuum) both affect the performance of aircraft and spacecraft inside and outside of the Earth's atmosphere. Aerospace engineers design and test aircraft and spacecraft as well as missiles and satellites to learn how air impacts flight.

Aerospace engineers recently were able to test how the air pressure on Mars affects the flight of a drone!



Show What you Know

Parallel and Perpendicular Lines

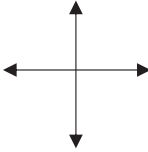
Parallel – straight lines extending indefinitely without ever touching 	Perpendicular – straight lines extending indefinitely and meeting at a ninety-degree angle 
--	--

Directions: Label each set of lines as parallel, perpendicular, or neither.

1. _____

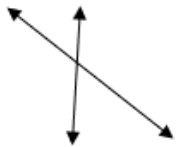

2. _____

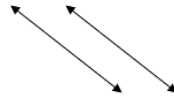

3. _____

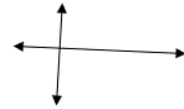

4. _____



5. _____



6. _____



7. _____

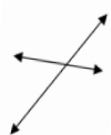

8. _____



9. _____



Revised with the permission of WGBH Educational Foundation ('WGBH') and/or Public Broadcasting Service ('PBS') (or other copyright holder indicated on the page). WGBH and/or PBS (or other indicated copyright holder) is not responsible for the content or accuracy of the revision.



Density Art



1. Scan the QR code on this sheet to watch the video and follow along with Mister C.



helps you



2. You'll need:

- a. This printout
- b. Plain printer paper or canvas paper
- c. Food coloring
- d. Vegetable Oil
- e. Pipette or straw
- f. Pan

Discussion Questions:

Does the type of paper impact the art?

How can you manipulate the colors to make more colors than you originally had in the food coloring box?

What if you added something like glitter to the oil and water mixture?

Fun Fact:

Symmetry is used in photography to create beautiful images. Butterflies have a line of symmetry down the center of their bodies.



A POND WITH A VIEW

DIFFICULTY: EASY

While there is action all around a pond, what do you think is happening *in* the water? Ponds are filled with animal and plant life that have special qualities that help them spend all or most of their lives underwater. Make this pond viewer to bring on your next pond exploration!



MATERIALS

- One-half gallon milk carton
- Scissors
- Waterproof, strong tape (e.g. duct tape) or a sturdy rubber band
- Heavy, clear plastic wrap

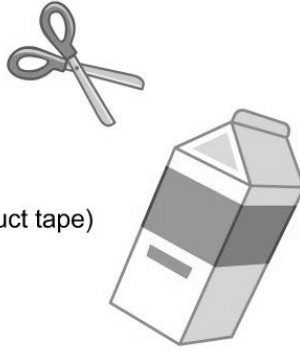

LET'S MAKE A POND VIEWER!

- 1 Have an adult cut off the very top of the milk carton and the very bottom to create a rectangular tube.
- 2 Tear off a sheet of plastic wrap and place it over one of the open ends. Fold down the plastic wrap... make sure wrap is smooth and tight for clear viewing.
- 3 Using the tape or the rubber band, secure the plastic wrap in place. Keep the plastic wrap as tight as possible so you have a flat viewing surface.

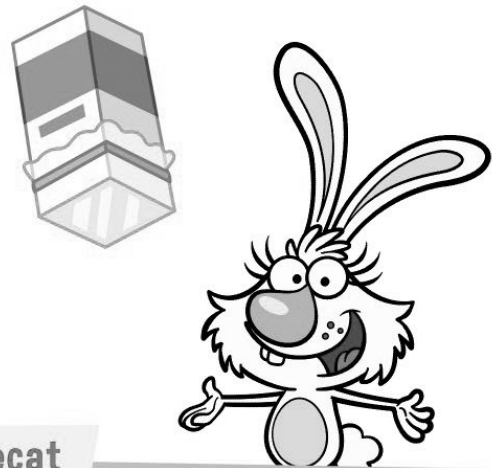

pbskids.org/naturecat

The PBS KIDS logo is a registered mark of PBS and is used with permission. © 2015 Spiffy Pictures. All rights reserved.



POND VIEWING TIPS

- 1 Splashing and stirring up mud will make it difficult to see into the pond. Be as still as possible when using your viewer.
- 2 Despite what NatureCat says, it is noble and fun to get wet! If the shoreline is murky, slowly wade out to your knees before using your viewer where it may be less murky.
- 3 Other ways to view: on a dock, over the side of a canoe, or in a stream, lake or tide pool!

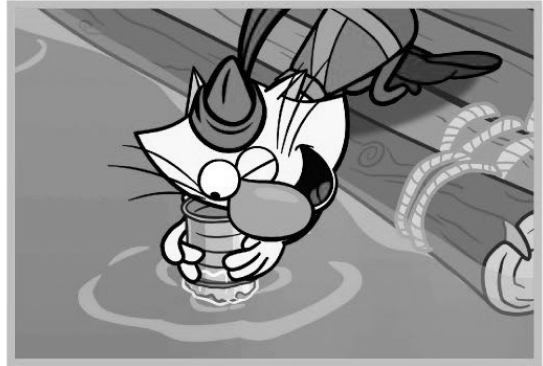

LET'S TAKE A CLOSER LOOK

Describe a plant or animal that you see. Draw a picture of it, and ask an adult to help you identify and label your picture.

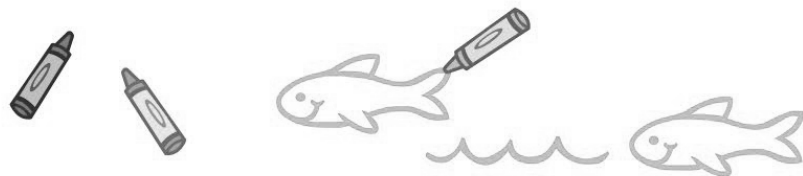

pbskids.org/naturecat

The PBS KIDS logo is a registered mark of PBS and is used with permission. © 2015 Spiffy Pictures. All rights reserved.

WEEK 3: HEROES



Complete activities and play BINGO!

Scan the QR code or visit Michiganlearning.org/summer to see video lessons for this week's activities. Use the boxes below to check off activities as you complete them. See if you can get a BINGO!



Superhero
Challenge
Row!
→

Watch Read, Write, ROAR!	Complete Page 30 Activity	Offer help to someone today	Complete Page 34 Activity	Write a thank-you note
Do three secret acts of kindness	Complete Page 39-40 Activity	Talk about your hero (Tell them if you can!)	Complete Page 36 Activity	Teach someone a safety tip
Do 20 superhero jumps	Run a superhero rescue lap	Crawl like a hero sneaking on a mission	Practice 3 superhero landings	Hold a hero power pose for 30 seconds
Complete Page 32 Activity	Watch Math Might	Complete Page 37-38 Activity	Week is over? Read your story with someone	Complete Page 35 Activity
Complete Page 31 Activity	Ask someone to help you today	Complete Page 33 Activity	Watch Michigan Learning Channel	Free Space

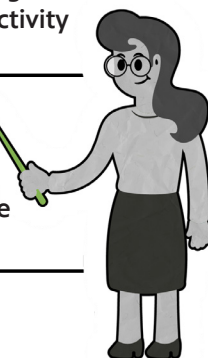

CREATE YOUR OWN HERO STORY!

The Story Pirates Hero Kit is a companion to our Hero Stories videos at storypirates.com/storypiratesuniversity. To get the most out of the Hero Kit, watch our videos as you go through these activities! We'll guide you as you brainstorm ideas, and then start to transform those ideas into a whole hero story.

Are you reading this on a computer or other device, but don't have a printer? No problem! You can still follow along with the Hero Stories videos, and brainstorm your ideas on blank paper.

As you go through the Hero Kit, you will...

- Create a **HERO CHARACTER**, and describe them in lots of rich detail!
- Decide on a gigantic, **HERO SIZED PROBLEM** that threatens an entire community!
- Plan how your hero will rise to the challenge and **SOLVE THAT PROBLEM!**
- Practice coming up with cool **DIALOGUE** for your hero to say!
- Start **WRITING** a story—or **DRAWING** a comic book! The choice is yours!

Whatever kind of hero you want to write about, just remember this: at Story Pirates, we've read all the hero comics, seen all the hero TV shows, played all the hero video games, and enjoyed all the hero poems. Now we're excited for something **NEW** and **DIFFERENT**. Your mission is to create a brand new hero that no one has ever heard of before.

The writing goals for the Hero Stories videos and our companion Hero Kit are in alignment with the **COMMON CORE STANDARDS**. As described in Writing Standard #3, students will establish detailed characters and situations, and structure the story with a logical sequence of events. Students will also explore how to use dialogue as a tool to move the story forward, and to flesh out the characters and events of a story effectively.



CREATE YOUR HERO

Time
to Draw!



Draw and label your hero!

Hero's name



DESCRIBE YOUR HERO

What are some words to describe your hero?

What is your hero really **GOOD** at, or what is your hero's **TALENT**?

What is your hero's **WEAKNESS**, or what is your hero **AFRAID** of?

What does your hero like to do on a **NORMAL DAY**, when they don't have a big problem to solve?



THE HERO SIZED PROBLEM

Every story involves some sort of problem, but in a hero story that problem is SO HUGE that a whole community is in danger, and a hero needs to save the day! For more ideas on how to create a Hero Sized Problem, check out our Hero Stories videos at storypirates.com/storypiratesuniversity.

What is the **COMMUNITY** where your story takes place? A city? A town? An underground snow fortress? Use your imagination, then draw and label a picture or map!

Time to Draw!



What is the **HERO SIZED PROBLEM** in the community?



CREATIVE SOLUTIONS

The Hero Sized Problems of today can't be solved just by punching, kicking, and blowing things up. Heroes need to be able to use their imaginations, and come up with creative ways to solve problems that nobody has ever thought of before. For more ideas on how to invent some **CREATIVE SOLUTIONS**, and then have your hero **TRY, FAIL, AND TRY AGAIN**, check out our Hero Stories videos at storypirates.com/storypiratesuniversity.

The **FIRST** solution the hero tried:

Unfortunately (what went wrong?):

The **NEXT** thing the hero tried:

Unfortunately (what went wrong?):

The solution that **FINALLY** worked:

It worked because:



DIALOGUE PRACTICE

A hero story needs lots of interesting dialogue. You want the reader to be able to hear it when your hero gives an inspiring speech, or whispers a secret plan, or makes a cool snappy comment. Practice writing some dialogue for your hero that you might put into a story later! For more ideas and information, watch our Hero Stories videos at storypirates.com/storypiratesuniversity.

Write some dialogue here. Use quotation marks, and check out the next page for some words you could use instead of “said”.

You can also draw your hero in an exciting scene, and add a speech bubble for what they’re saying.

SHOW **NOT TELL!**

THE STORY PIRATES
CREATOR CLUB



Character Traits

Who is your character?	Choose a character trait to describe them. There are some suggestions below!
SHOW the character trait to the reader! Write about what the character is DOING because of that trait.	

Other words for "kind"

considerate
generous
helpful
thoughtful

Other words for "energetic"

exuberant
lively
spirited
vivacious

Other words for "friendly"

affable
amiable
gregarious
welcoming

Other words for "funny"

amusing
comical
hilarious
silly

Other words for "wise"

knowledgable
perceptive
prudent
shrewd

Other words for "unfriendly"

antisocial
disagreeable
hostile
rude

Other words for "lazy"

lackadaisical
lethargic
passive
weary

Other words for "hard-working"

diligent
industrious
persevering

SHOW **NOT TELL!** Emotion



What **emotion** would you like to "Show, Not Tell"? Pick one from the examples below, or just choose your own! If you're not sure what some of the words mean, look at the picture of the face for a clue.



Elated



Jubilant



Thankful



Gloomy



Sorrowful



Lonely



Anxious



Petrified



Startled



Frustrated



Furious



Irate



Amazed



Bewildered



Shocked



Inquisitive

Who is your character?	SHOW the emotion to the reader. What does the character SAY because they feel that way?
What emotion are they feeling?	

DRAW YOUR STORY!

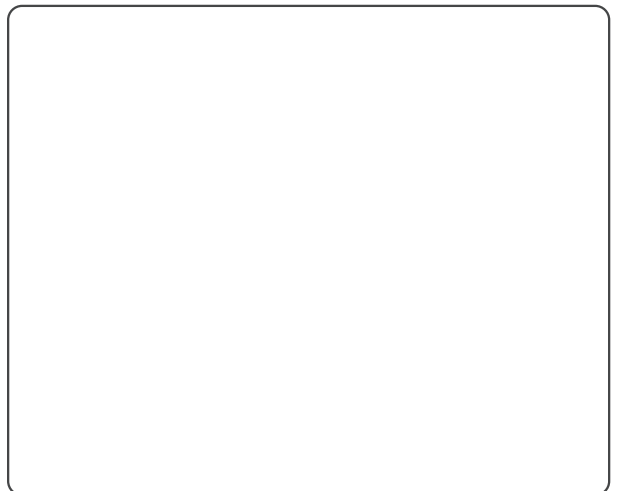
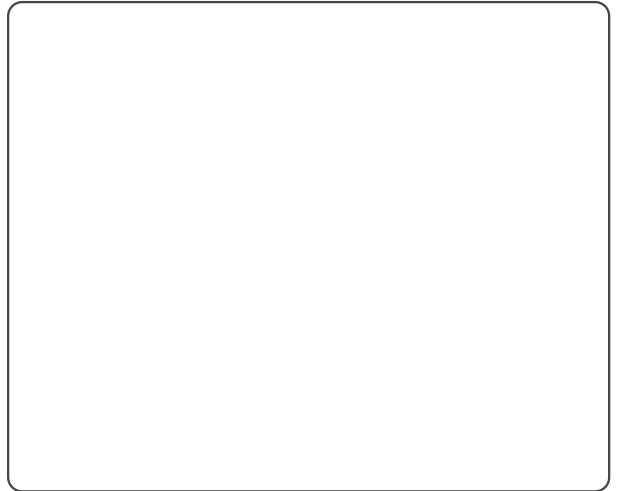
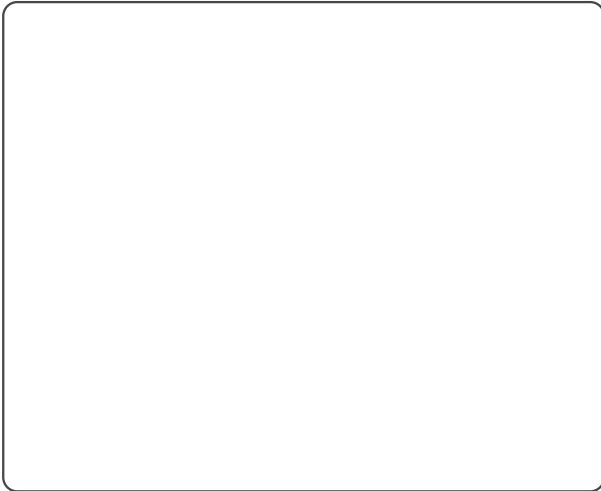
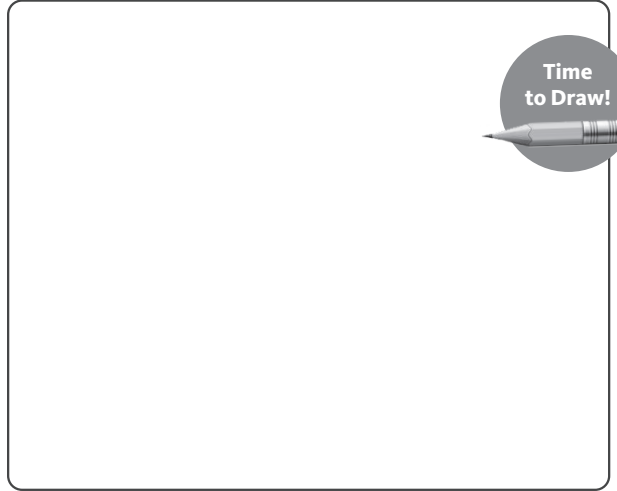
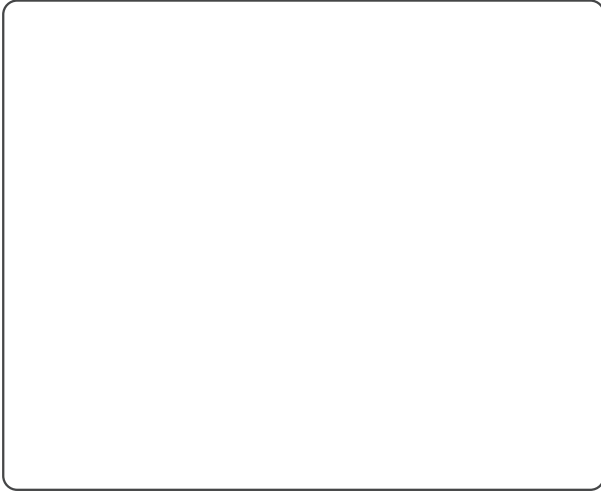

DRAW YOUR STORY!

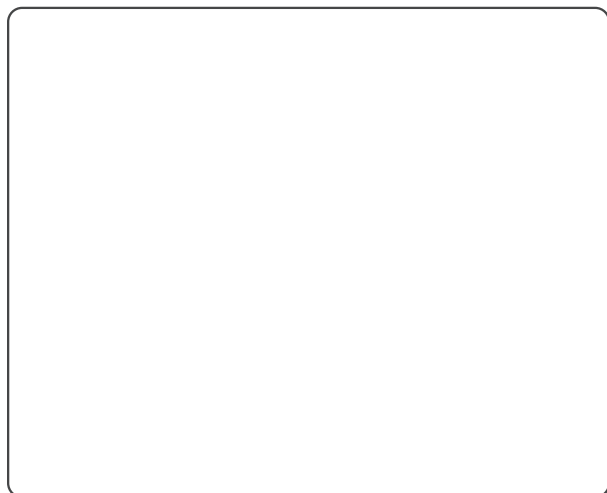
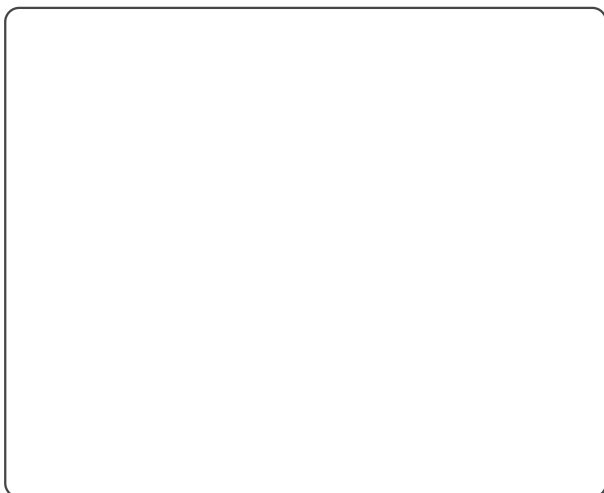
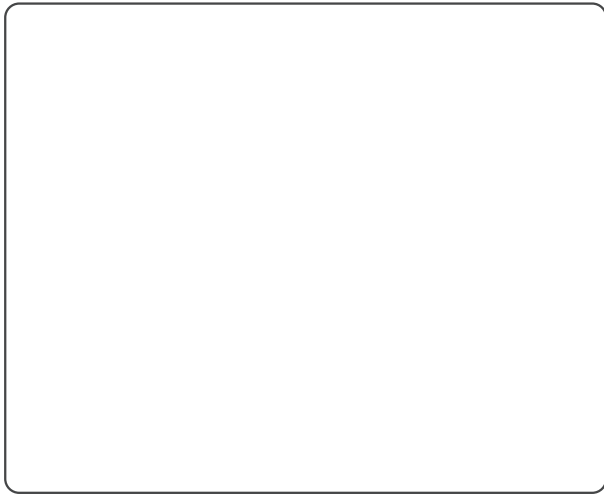

Thanks for using our Hero Kit! If you've written a story and want to share it with us, please have a grownup go to storypirates.com/submit-a-story.

WEEK 4: CREATURES

Complete activities and play BINGO!

Scan the QR code or visit [Michiganlearning.org/summer](https://michiganlearning.org/summer) to see video lessons for this week's activities. Use the boxes below to check off activities as you complete them. See if you can get a BINGO!



Watch Read, Write, ROAR!	Share a snack with someone	Sketch an animal in motion	Build a tiny home for a creature	Photograph an animal or insect
Research a local animal	Complete Page 42-43 Activity	Watch Wimee's World	Teach someone an animal fact	Read to a younger kid
Find a creature larger than your foot	Observe a bug for five minutes	Free Space	Build an animal habitat with sticks	Complete Page 44 Activity
Complete Page 45 Activity	Watch Math Mights	Move like five animals	Find a creature smaller than your thumb	Complete Page 46-47 Activity
Look for a creature awake at night	Complete Page 48 Activity	Read a book about animals	Watch PBS KIDS	Rest outside for 20 minutes



DIY Elephant Toothpaste



FUN FACT

Seaweed is in our toothpaste! Seaweed acts as a thickening agent that allows toothpaste to be squeezed from its tube!

MATERIALS

- Yeast
- Dish soap
- Measuring spoons
- Empty plastic bottle
- Cup with warm water
- 3% Hydrogen peroxide

DIFFICULTY



CHEMICAL REACTIONS

Chemical reactions take place when the molecular or ionic structure of a substance is rearranged. When a chemical reaction occurs, a new substance is created and the process is irreversible. Today we will be making elephant toothpaste!

VISIT

DIYSCIENTIME.ORG
FOR MORE SCIENCE FUN!



Why are chemists great at solving problems?

*Answer on the next page

Copyright Alabama Public Television and Mister C, LLC 2021

DIY SCIENCE TIME

"Science is wherever YOU are!"



DIY Elephant Toothpaste

EXPERIMENT

- Step 1:** Gather materials.
- Step 2:** Place 2 tablespoons of yeast into 3 oz of warm water.
- Step 3:** Mix yeast and warm water, let stand until it gets frothy (about 3 minutes).
- Step 4:** Pour 4 ounces of hydrogen peroxide into an empty bottle.
- Step 5:** Squirt 1 tablespoon of dish soap into the hydrogen peroxide.
- Step 6:** Pour your yeast mixture into the bottle.
- Step 7:** Observe what happens!

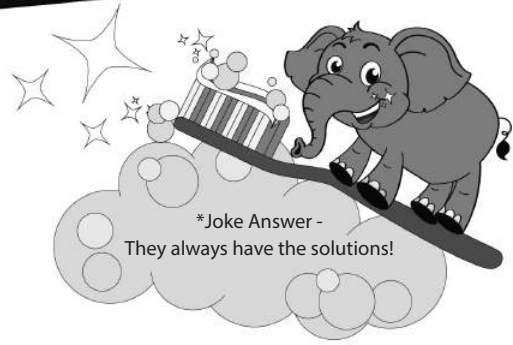

WHY IT WORKS

"Elephant toothpaste" is created when a chemical reaction takes place and releases one oxygen atom from the hydrogen peroxide (H_2O_2). Hydrogen peroxide decomposes, or breaks down, into water (H_2O) and oxygen (O_2) naturally over time, but the yeast causes this to occur faster. The yeast has an enzyme in it called catalase. Catalase is a catalyst, something that increases the speed of the reaction. The catalyst is what causes the oxygen to be released quickly to create our "elephant toothpaste." So why did we add soap? We wanted to capture all of the released oxygen (gas) from the chemical reaction!

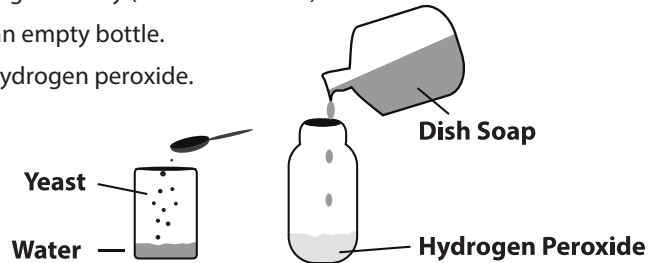

EXTEND YOUR LEARNING

- Would the experiment still work if you added more yeast?
- What happens if you don't add the soap?
- Does the shape or the size of the bottle change how the elephant toothpaste flows?

WORKFORCE CONNECTION

Cosmetologists, people who study the application of beauty treatments, work carefully with chemical reactions on a daily basis to help color people's hair. When someone's hair is bleached, a chemical reaction takes place to change the melanin from brown to a colorless (pale yellow) color. This irreversible process (chemical change) then allows the cosmetologist to apply a new color to the hair.



Independent Practice

Directions: On a separate sheet of notebook paper, solve each of the following problems using the method described and shown on the previous page.

1. Your basketball team just won the tournament! As a reward, your coach is taking the whole team, plus the assistant coaches, to get hamburgers and milkshakes. Before leaving the ballpark, your coach calls the restaurant and places an order for seventeen hamburgers and fourteen milkshakes (three people requested no shake). Once you all arrive at the restaurant, the order comes up short. It seems the coach miscounted, and now there are several people without food. If there are twenty players including yourself, two assistant coaches, and the head coach, how many *additional* hamburgers and milkshakes will need to be ordered so that everyone can have one burger and one milkshake?
2. At your school, rows of lockers are twenty lockers long and stacked two high. Odd numbers are on the top, and even numbers are on the bottom. You were assigned locker number 7. Your friend Kristi was given a locker five places to the right of yours and on the bottom row. Your cousin Sam was given the locker directly above Kristi's. Which lockers were assigned to Kristi and Sam?
3. Yearbook Club is raising money for a new camera. The camera they want costs \$1,960, and they already had \$165 in the bank before they started raising money. In February, the club raised \$492 by selling candy bars. This past month, the club raised triple the amount raised in February by selling tickets for a pie-the-principal-in-the-face contest. Of course, Yearbook Club doesn't get to pocket all of the money it raised. The club will have to pay for the supplies they bought in order to host the fundraisers. Their total expenses came to \$307. How much money does the club have now? How much money do they still need to raise before they can buy their camera?

Revised with the permission of WGBH Educational Foundation ('WGBH') and/or Public Broadcasting Service ('PBS') (or other copyright holder indicated on the page). WGBH and/or PBS (or other indicated copyright holder) is not responsible for the content or accuracy of the revision.



URBAN SPRAWL HAIKU



ACTIVITY GUIDE

SCAN TO WATCH LESSON



EPISODE 112: WILDLIFE HABITS

Mr. Kass explained the concept of urban sprawl and explained how Haiku, a form of Japanese poetry, often explores the intersection between the natural world and the human-built one. He then talked us through how to write a Haiku that attempts to explore that intersection.

1. Read Mr. Kass' examples of Haiku.
2. Think about areas you've experienced where it seems like the natural world is intersecting with the human built one.
3. Write your own Haiku where you explore that intersection. Try to write at least 4-5 Haiku.

Mr. Kass' Haiku

#1

On the lake bottom
a walleye peeks into
the nose of a soda bottle

#2

Mist rises above a stand
of Michigan pines
and a cell phone tower

#3

In the dumpster
behind a restaurant's kitchen
the glint of a raccoon's eye



Design Your Own Plant Superhero

Big Idea: There are many different types of plants. Some types of plants are good at cleaning the air to make it better for us to breathe.

Explore: Below are three different types of plants. All of these plants are good at cleaning the air inside your house to get rid of pollutants. Pollutants are small, unhealthy things that can get into the air, sometimes from new rugs or cleaning supplies. These plants breathe in the pollutants when they take in air, making it healthier for us inside.



Peace Lily



Areca Palm



Snake Plant

Look at the three plants above. What do you notice that all of these plants have in common (What color are they? What parts of the plant do you see?) What do all plants need?

How are these plants different from each other?

(continued on page 2)

For more *Cyberchase* adventures with plants, watch “Plantasaurus” on pbskids.org/cyberchase.

Funding for *Cyberchase* is provided by The JPB Foundation, the Heising-Simons Foundation and Ernst & Young LLP. Additional funding is provided by Lynne and Marc Benioff, the Tiger Baron Foundation, Shailaja and Umesh Nagarkatte and Ellen Marcus.

Cyberchase is a production of THIRTEEN Productions LLC for WNET. ©THIRTEEN Productions LLC. All rights reserved. PBS KIDS and the PBS KIDS logo are registered trademarks of PBS. Used with permission.





AT-HOME ACTIVITY

Design Your Own Plant Superhero

DRAW PAGE

Take turns drawing your plant superhero on this page. Start with the top section and make sure to draw down just below the dotted line. Fold over the top section when you are done and pass on to the next person for the middle section.

Fold back here when top section is done.

Fold back here when middle section is done.

(continued on page 4)

Funding for *Cyberchase* is provided by The JPB Foundation, the Heising-Simons Foundation and Ernst & Young LLP. Additional funding is provided by Lynne and Marc Benioff, the Tiger Baron Foundation, Shailaja and Umesh Nagarkatte and Ellen Marcus.

Cyberchase is a production of THIRTEEN Productions LLC for WNET. ©THIRTEEN Productions LLC. All rights reserved. PBS KIDS and the PBS KIDS logo are registered trademarks of PBS. Used with permission.





My Creature Adventure



Instructions: Anyone can write their own creature adventure. You just need to choose your creature, select your setting (where the adventure takes place), and decide on the plot (what happens to the creature in the setting). Try for yourself!

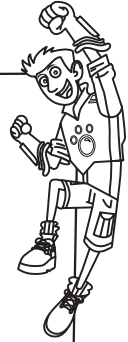
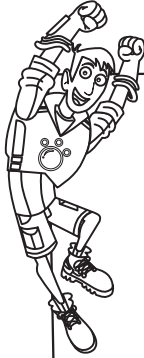

A large rectangular writing area with a solid top line and a solid bottom line. Inside, there are 18 horizontal dashed lines for writing.

Find more games and activities at pbskidsforparents.org

PBS KIDS and the PBS KIDS Logo are trademarks owned by Public Broadcasting Service. Used with permission. Wild Kratts® © 2025 Kratt Brothers Company Ltd./ 9 Story Media Group Inc. Wild Kratts® and Creature Power® are owned by Kratt Brothers Company Ltd.

WEEK 5: ENGINEERING

Complete activities and play BINGO!

Scan the QR code or visit [Michiganlearning.org/summer](https://michiganlearning.org/summer) to see video lessons for this week's activities. Use the boxes below to check off activities as you complete them. See if you can get a BINGO!



Watch Read, Write, ROAR!	Build the tallest tower you can	Complete Page 50-51 Activity	Stretch your body for 5 minutes	Complete Page 57-58 Activity
Design a launcher to send something flying	Sit quietly outside for 15 minutes	Watch Wimee's World	Make a bridge from household items	Go on a flashlight adventure at dusk
Complete Page 54-55 Activity	Read a comic or graphic novel	Free Space	Create a marble or ball ramp	Complete Page 52 Activity
Teach someone a game you like	Watch Math Might	Complete Page 53 Activity	Take a 10-minute quiet break	Follow a butterfly or bird for 5 minutes
Complete Page 56 Activity	Build a secret hideout or fort	Invent a tool to solve a problem	Watch PBS KIDS	Build a tower using only paper



DIY Marble Madness



FUN FACT

Before roller coasters were even invented, mountain-side railway cars carried coal in the mornings and provided joy rides for human passengers in the afternoon. The Mauch Chunk Switchback Railway was built in 1827 and could carry its passengers 50 miles per hour!

POTENTIAL AND KINETIC ENERGY

Energy stored in an object due to its position is potential energy. Energy that a moving object has due to its motion is kinetic energy. We can observe potential and kinetic energy conversions in many different places. Roller coasters, sledding, and even playing with dominos are familiar examples of potential and kinetic energy.

MATERIALS

- Marbles
- Straws
- Tape

DIFFICULTY



Why is wind energy becoming so popular?

**Answer on the next page*

VISIT
DIYSCIENTIME.ORG
FOR MORE SCIENCE FUN!



Copyright Alabama Public Television and Mister C, LLC 2021

DIY SCIENCE TIME

"Science is wherever
YOU are!"



DIY *Marble Madness*



*Joke Answer -
Because it has so many fans!



EXPERIMENT

- Step 1:** Build a track that allows a marble to roll across the straws. Try to make a track 10 feet in length.
- Step 2:** Build a ramp for your track. This is where your marble will start and get its energy.
- Step 3:** Release your marble onto the track and observe the distance and speed your marble is able to reach.
- Step 4:** Did your marble make it the entire length of the track? How long did it take? Record your data into your science notebook.
- Step 5:** Redesign your track and ramp to increase the speed and distance the marble can travel.

WHY IT WORKS

Marbles have mass, and when you lift mass up off the ground, you increase the potential energy that mass has because of gravity. By adjusting the height of your ramp, you are able to increase or decrease the potential energy of the marble. Once the marble is released, it rolls down the track and the potential energy is converted into kinetic energy. If your ramp is tall enough and your track is built well, the marble may be able to successfully travel the entire track. With some simple adjustments, you can increase and decrease the speed of the marble.

EXTEND YOUR LEARNING

- What's the longest track you can build?
- Does the size of your marble change the distance that it can travel?
- Can you add hills to your track? How does that impact how the marble travels?
- Try building a second track and race a friend.

WORKFORCE CONNECTION

Hydroelectric power plants use gravitational potential energy to turn the blades of a turbine to generate electricity. A hydroelectric power plant has a water reservoir that sits above the turbines, giving the water potential energy. Scientists precisely regulate the flow of the water down and out of the reservoir, directing it across energy generating turbines. These scientist must precisely calculate the amount of water speed necessary to get the turbines moving to generate electricity.



PLACE VALUE

Directions: Write each number in expanded form.

1. 4,057 _____

2. 6,784 _____

3. 3,182 _____

4. 9,557 _____

5. 4,586 _____

6. 5,037 _____

7. 2,233 _____

8. 10,000 _____

9. 5,281 _____

10. 4,585 _____

Revised with the permission of WGBH Educational Foundation ('WGBH') and/or Public Broadcasting Service ('PBS') (or other copyright holder indicated on the page). WGBH and/or PBS (or other indicated copyright holder) is not responsible for the content or accuracy of the revision.



WHY IS LANSING MICHIGAN'S CAPITAL?



ACTIVITY GUIDE

SCAN TO WATCH LESSON



EPISODE 102: MAKING MICHIGAN

Persuasive writing is used to help win people over to your opinion. Think of something you believe in strongly, or maybe make up a funny or silly idea use the graphic organizer below to help frame your ideas to write a persuasive letter.

Introduction: State your opinion clearly.

Reason 1: Explain why you think your opinion is right.

Reason 2: Provide a second reason, and provide some evidence.

Reason 3: Explain how your opinion helps other people.

Conclusion: Summarize your opinion and state what you'd like your reader to do.



MAKE A COMPOSTER!

DIFFICULTY: EASY (REQUIRES ADULT ASSISTANCE)

What happens to a pile of old leaves outside when you add a dash of time, maybe some worms, and a healthy splash of moisture? Rich soil perfect for a garden just like Daisy's!



MATERIALS

- 1 empty two-liter soda bottle
- Sharp knife
- Nail
- Shredded newspaper
- Dirt (not potting soil -- use dirt from outside)
- Compost materials (such as grass clippings or vegetable scraps)
- Small handful of dead leaves
- Flat dish to hold compost
- Spray bottle with water

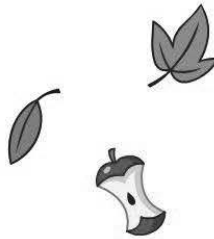

LET'S GET COMPOSTING!

- 1 Rince the bottle and peel off the label.
- 2 Have a grownup cut off the top of the bottle as shown. Set the top aside.
- 3 Have the grownup use the nail to punch 8 to 10 small air and drainage holes along the sides and bottom of the bottle.
- 4 Put the bottle on the tray.

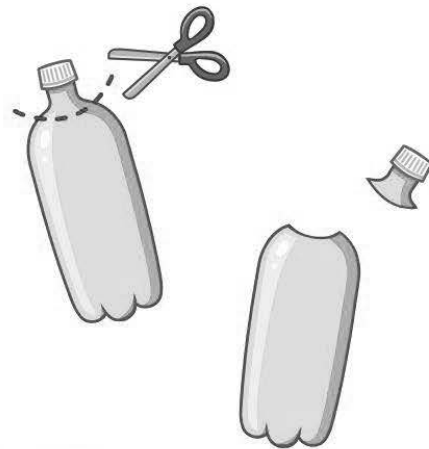

pbskids.org/naturecat

The PBS KIDS logo is a registered mark of PBS and is used with permission. © 2015 Spiffy Pictures. All rights reserved.



- 5 Put some dirt, shredded newspaper and old leaves inside the composter. This is your compost starter.
- 6 Use the spray bottle to wet the compost starter.
- 7 You're ready to add some stuff to your compost! (Try grass clippings, vegetable scraps, coffee grounds, or eggshells, but do not add dairy or meat.)
- 8 Turn the bottle top upside down and nest it in the open top of the bottle. It will act like a funnel for adding a little bit of water each day to keep the contents damp.
- 9 Place in a spot where sunlight can reach it.
- 10 Stir every few days, keep the contents damp, and let it rot! As your compost breaks down, you can add more kitchen scraps or plant litter, as well as some more soil from outside to mix in.
- 11 Cover the top of your compost with a kitchen towel when not in use.



LET'S TAKE A CLOSER LOOK

- 1 As you check your composter each day, describe what you observe.
- 2 You may see fluffy mold growing. Some people are allergic to some types of mold, so keep your compost covered when you're not working with it.
- 3 Now take your rich, healthy soil, place it in a pot, add a seed and some water and grow your very own plant!

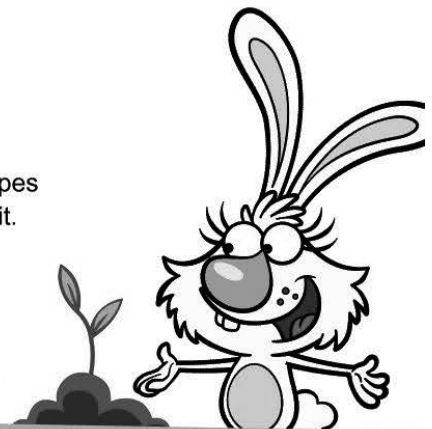

pbskids.org/naturecat

The PBS KIDS logo is a registered mark of PBS and is used with permission. © 2015 Spiffy Pictures. All rights reserved.



<https://michiganarchitecturalfoundation.org>



ArchiTREKS: Landmarks

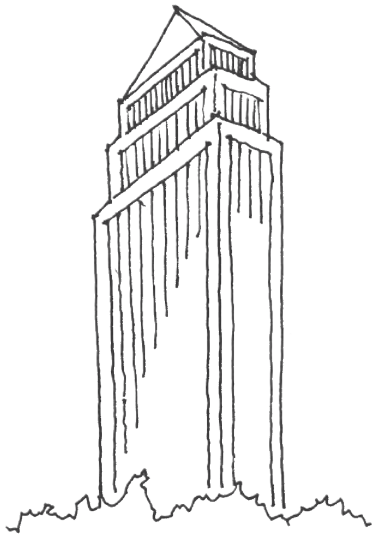

High-Rise Building

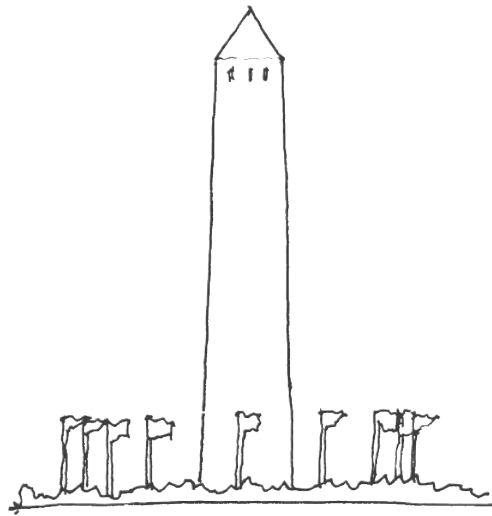

Monument



Church Steeple

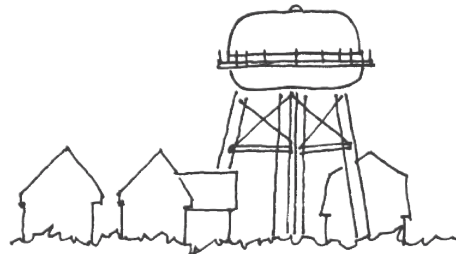

Water Tower

These are examples of landmarks. What landmarks are in your neighborhood? Draw a picture of a local landmark!



Coding With Cards

Practice basic coding concepts in a fun and interactive way using playing cards.

Command - A command is an instruction given by a user to perform a specific task.

Sequence - Sequence means, "in a row", so a sequence in coding is a set of instructions or tasks performed in a specific order.

Loop - A loop is a sequence of instructions that is continually repeated until a certain condition is reached.

Condition - A condition is usually an if/then statement, where an action is performed if that statement is true.

To Play:

1. Form four teams of 2-5 players each.
2. Learn the coding words together until every player knows what each word means.
3. Set up a game grid:

Lay out the grid paper on the table or floor.

Each square in the grid represents a space where you will navigate your game piece.

- Write START at one end of grid paper, in any square the team chooses.
 - Write FINISH on the opposite end of the paper, in any square the team chooses.
4. Each player decorates a game piece like a robot or digital character.
 5. Your team is now ready to play!

GAME ONE:

Assign **Commands** to your playing cards.

- To start, we'll all use the same commands:
 - ♥ Hearts - Move forward one space.
 - ♦ Diamonds - Turn Right and move forward one space.
 - ♣ Clubs - Turn Left and move forward one space.
 - ♠ Spades - Move forward two spaces.
- Each player takes turns drawing a card and following the commands by moving their game piece around the board.
- The player that reaches the finish space first, wins. **OPTIONAL:** The player that gets closest to the finish space after playing for 5 minutes, wins.

GAME TWO:

Create and test **Sequences**.

1. Shuffle the deck of cards and deal a sequence of 10 cards to each player.
2. Players will take turns laying out their sequence of cards and moving their game piece on the grid.
3. The player who gets closest to the finish space, wins.

Experiment by rearranging the cards and following the new sequences to see if players achieve different outcomes.

GAME THREE:

Add **Loops** and **Conditions**.

1. Shuffle the deck of cards and deal a sequence of 10 cards to each player.
2. Players will take turns laying out their sequence of cards and moving their game piece on the grid.
3. Use numbered cards to add special rules to represent **Loops**::
 - Aces, 2s and 3s: repeat your last command three times.
 - 4s, 5s and 6s: repeat your last sequence five times.

WEEK 6: THE GREAT OUTDOORS

Complete activities and play BINGO!

Scan the QR code or visit [Michiganlearning.org/summer](https://michiganlearning.org/summer) to see video lessons for this week's activities. Use the boxes below to check off activities as you complete them. See if you can get a BINGO!



Watch Read, Write, ROAR!	Go on a 15-minute nature walk	Complete Page 62 Activity	Collect 3 interesting rocks	Walk bare-foot in the grass
Build a stick shelter	Complete Page 65 Activity	Watch Wimee's World	Visit a local park nearby	Find 5 different leaves
Sit by a tree and draw what you see	Complete Page 60-61 Activity	Free Space	Create a map of your town	Complete Page 63 Activity
Find a bug carrying something	Watch Math Might	Watch the sunset or sunrise	Look for shadows outside	Find something red, yellow, and green outside
Find a leaf bigger than your hand	Find a tree bigger than you home	Complete Page 64 Activity	Watch PBS KIDS	Find something that smells good outside



DIY Heatless Lava Lamp



FUN FACT

Lava lamps were invented in 1948 and were originally called "Astro Lamps." The lava lamp made its television debut in the US in the 1960s on a show called "Doctor Who." Sales skyrocketed after this TV appearance!

MATERIALS

- 2-liter bottle
- Vegetable oil
- Water
- Effervescent tablets
- Food coloring
- Funnel

DIFFICULTY



DENSITY

Density is a measurement of the matter an object has within a given volume. Objects with more matter in a given volume have a higher density. Objects with less matter in the same amount of volume have a lower density. Density is found by dividing the mass of an object by its volume.

VISIT
DIYSCIENTIME.ORG
FOR MORE SCIENCE FUN!



*What runs but
never walks?*

*Answer on the next page

Copyright Alabama Public Television and Mister C, LLC 2021

DIY *Heatless Lava Lamp*

EXPERIMENT

- Step 1:** Gather your materials.
- Step 2:** Clean and rinse your empty 2-liter bottle.
- Step 3:** Pour 3 cups of water into your bottle.
- Step 4:** Add food coloring to the water.
- Step 5:** Gently pour vegetable oil into the bottle and observe how the water and oil interact.
- Step 6:** After allowing the water and oil to settle, drop pieces of the effervescent tablets into the bottle.
- Step 7:** Observe what happens!

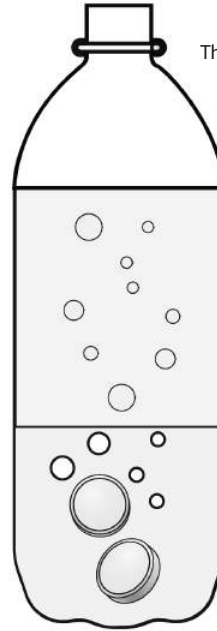

*Joke Answer -
The water from your faucet!

WHY IT WORKS

The oil and water stay separate because they have different densities. The oil floats on the water because it's less dense than water. When the effervescent tablet sinks to the bottom, it mixes with the water and starts a chemical reaction that produces carbon dioxide, a gas that rises through the oil. When these bubbles rise, they pull some of the colored water up and through the oil. The gas eventually escapes at the top, but the water falls back down through the oil because it is more dense!

EXTEND YOUR LEARNING

- What happens if you add more pieces of effervescent tablet, or change the amount of water in the bottle?
- Try shining a light, like a flashlight, through the bottle. What can you see differently?
- Is there a limit to the number of times you can repeat the experiment?

WORKFORCE CONNECTION

Paint chemists are scientists who study the properties and use of paint. Most paints are made of the same basic ingredients: pigments, binders, liquids, and additives. How these ingredients interact due to their densities plays an important part in determining the way that paint performs. Paint chemists study things like how well a paint can cover a surface or how long a paint may be able to last outside in the weather.



Show what you know!

Math Time: Clothesline Math

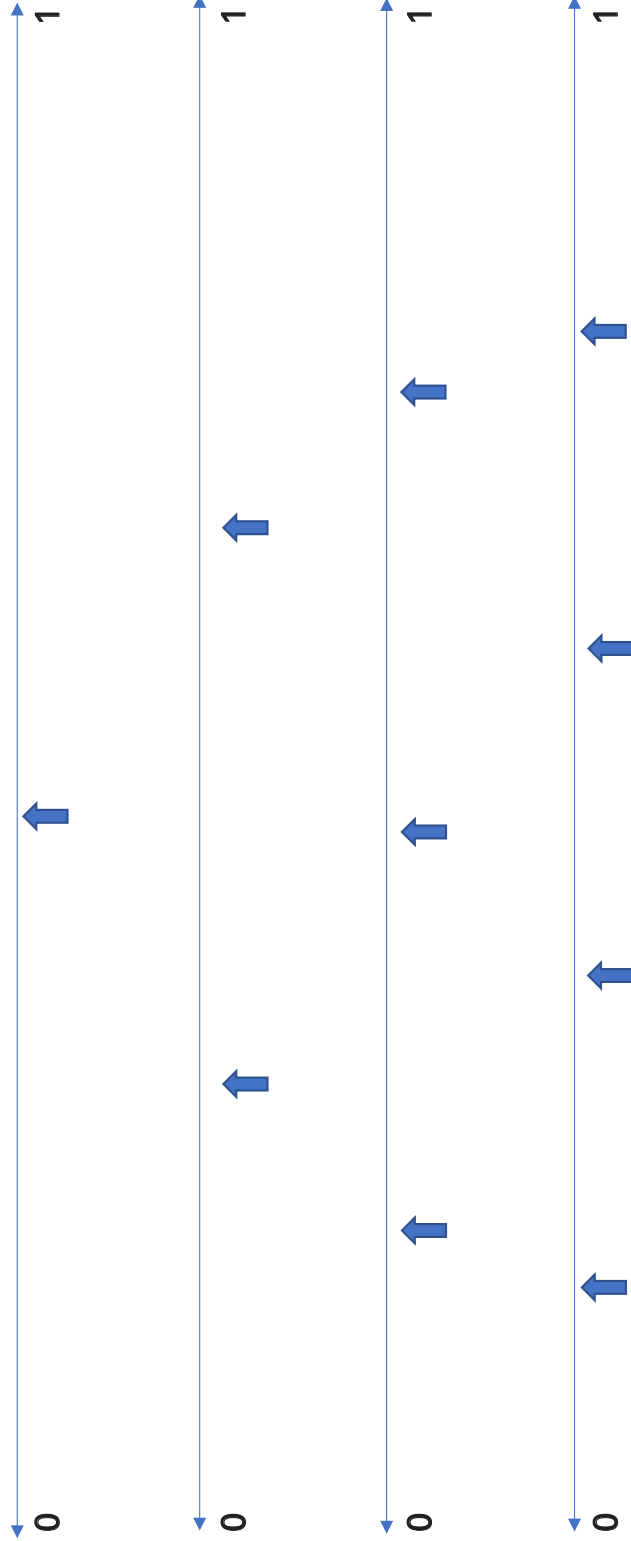

Revised with the permission of WGBH Educational Foundation (WGBH) and/or Public Broadcasting Service (PBS) (or other copyright holder indicated on the page). WGBH and/or PBS (or other <https://detroitpbs.org/turning-pizza-into-fractions-video/rise-and-shine-math-time/> indicated copyright holder) is not responsible for the content or accuracy of the revision.



LAKE EFFECT SNOW AND DIALOGUE



ACTIVITY GUIDE

SCAN TO
WATCH LESSON



EPISODE 103: WHAT'S UP WITH THE WEATHER?

What interests you and would make a great story? Use the three-column chart below to organize your writing into three parts.

<i>BEGINNING</i>	<i>MIDDLE</i>	<i>ENDING</i>



Make Leaf and Bark Rubbings

Instructions

1. You'll need one or more crayons with the labels removed, some cardboard or a clip board and some masking tape to help hold leaves or bark in place.
2. When you're walking outside, collect a few fallen leaves, some bark or other natural materials. It's best if you find leaves or bark where you can feel bumps or ridges.
3. Once you've found your leaves, bark or other items, use tape to secure the edges of the leaves, bark or other materials to the clipboard or cardboard so that they will stay in place while you make your rubbing.
4. Place this paper over the leaves and bark and lightly rub the side of the crayon over the surface of the paper, just hard enough so that the texture shows.
5. Write a list of words to describe how the leaf or bark feels or looks like.

What You'll Need:

- Trees
- Plain white paper
- Crayons with label removed
- Masking tape (optional)
- Cardboard or clipboard
- Paper bag for collecting leaves



Find more games and activities at pbskidsforparents.org

PBS KIDS and the PBS KIDS Logo are registered trademarks of Public Broadcasting Service. Used with permission. NATURE CAT and associated characters, trademarks and design elements are owned by Spiffy Entertainment, LLC © 2016 Spiffy Entertainment, LLC. All rights reserved. Major funding for the series is provided by the Corporation for Public Broadcasting (CPB) and the Van Eekeren Family, founders of Land O'Frost. Additional funding: The Hamill Family Foundation, The Segal Family Foundation, The Arthur Vining Davis Foundations, Polk Bros. Foundation, Alvin H. Baum Family Fund, Boblink Foundation, Sage Foundation, The David E. Zyer Family, Dr. Scholl Foundation, and Colonel Stanley R. McNeil Foundation.

Environmental Science Issues

The video “Environmental Science Issues” discusses the importance of our environment and the steps that we can take to help protect it. Taking care of the environment is everyone’s responsibility.

Try This!

Use the space below to draw your favorite environment. It might be a beautiful beach, a tranquil park, a wild forest, or anywhere that you would love to be. Then answer the questions that follow.

My Favorite Environment

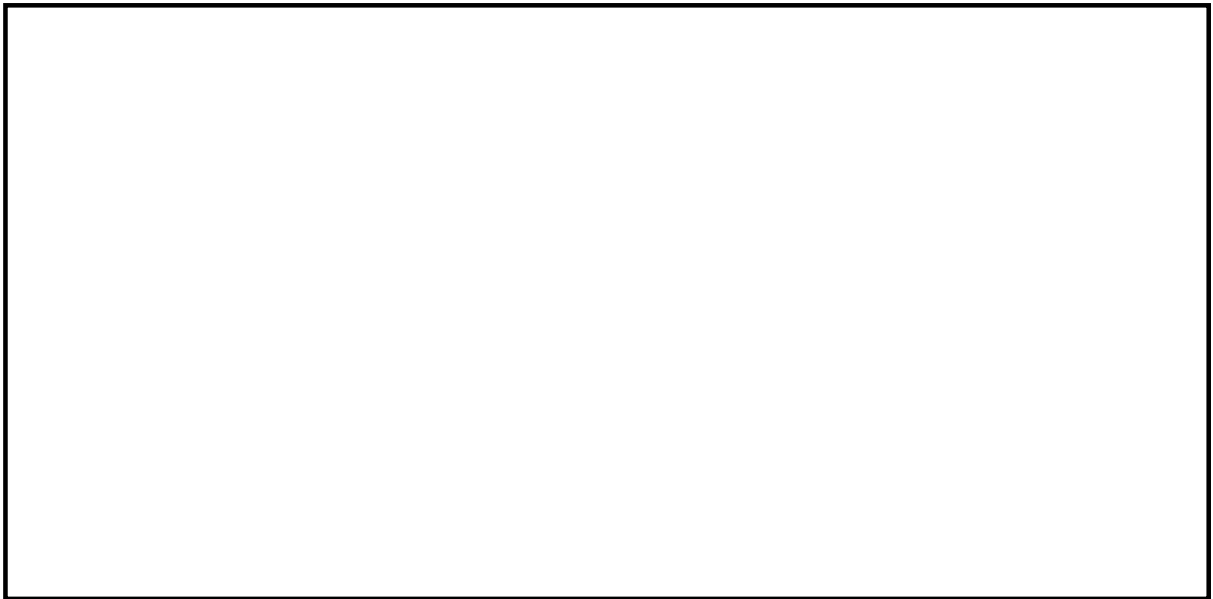

What makes this your favorite environment?

What threats does your favorite environment face? For example, what might happen if someone came and cut down the trees or dumped trash on the beach?

What could you do to help protect your favorite environment?

WEEK 7: WHEN I GROW UP

Complete activities and play BINGO!

Scan the QR code or visit [Michiganlearning.org/summer](https://michiganlearning.org/summer) to see video lessons for this week's activities. Use the boxes below to check off activities as you complete them. See if you can get a BINGO!



Watch Read, Write, ROAR!	Learn a new skill from someone	Complete Page 67 Activity	Interview an adult about their job	Imagine your dream job — draw it!
Drink a 5 glasses of water today	Write a letter to your future self	Watch Wimee's World	Think of a job that helps your community	Complete Page 68-69 Activity
Complete Page 70-71 Activity	Take a 10-minute quiet rest	Free Space	Ask someone what they wanted to be as a kid	Make a poster for a local business
Take a screen-free break for 30 minutes	Watch Math Mights	Create your own business for a day	Complete Page 72 Activity	Think of a job that helps animals
Try helping with a chore or task	Complete Page 73 Activity	Teach someone a new skill	Watch PBS KIDS	Sit in the shade



TELLING INTERGENERATIONAL STORIES



ACTIVITY GUIDE

SCAN TO WATCH LESSON



EPISODE 106: LET'S TALK TOGETHER

Rather than screen time, spend time talking!



**Traveling
Conversations**



Walk & Talks

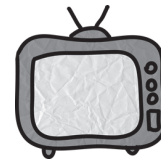

**Share connections
with
books & shows**

Conversation Starters

- Tell me about a time you laughed really hard.
- Share a memory about when you felt embarrassed.
- How did you feel learning something new?
- What was your favorite toy when you were a kid?

DIY Electroscope



FUN FACT

Lightning is a form of static discharge and lightning strikes have been recorded at distances of 10 miles. If you are close enough to hear thunder, it's important to take shelter.

MATERIALS

- Glass jar or cup
- Straw
- Cardstock
- Scissors
- Copper wire
- Pencil
- Aluminum foil
- Balloon

DIFFICULTY



STATIC ELECTRICITY

Static electricity is a stationary electric charge. This charge is typically produced by rubbing two objects together. The friction causes electrons to transfer from one object to another to create a build up of electrons, or static charge.

VISIT
DIYSCIENTIME.ORG
FOR MORE SCIENCE FUN!



What happens if you plant a lightbulb in a garden?

**Answer on the next page*

Copyright Alabama Public Television and Mister C, LLC 2021

DIY Electroscope

EXPERIMENT

Step 1: Create a card stock lid for the top of your jar (about 1 inch larger than the jar). Carefully pierce a hole in the center of your lid.

Step 2: Cut the straw to approximately 3 inches in length and push through the hole in your card stock lid.

Step 3: Cut a length of the copper wire approximately 10 inches. Use approximately 4 inches of one end of the wire to create a flat spiral. Run the straight end of the wire down, through the straw and into the jar.

Step 4: Carefully cut two, 1 inch oval-shaped pieces of aluminum foil. Pierce a small hole in one end of each piece and using the copper wire inside the jar as a hook, hang them next to each other inside the jar.

Step 5: Use your electroscope to detect static charge on different objects by placing them near the wire spiral.

Step 6: Hold the blown up balloon up to the wire spiral of your electroscope. Then try rubbing the balloon against your hair and then hold the balloon to the wire spiral of your electroscope and observe any differences.

*Joke Answer -
You grow a power plant!



WHY IT WORKS

Rubbing a balloon against your hair transfers electrons from your hair to the balloon. This transfer of electrons will cause the balloon to become more negatively charged. When you move the balloon closer to the electroscope, this will cause the negatively charged electrons on the copper wire to move down and away from the balloon. The electrons move down the copper wire and transfer onto the pieces of foil. Now both pieces of foil have the same charge and want to repel one another. This causes the aluminum pieces to spread apart.

EXTEND YOUR LEARNING

- What other objects can you test?
- Could you create a scale to measure how far your aluminum pieces separate?
- What do you think causes them to separate more or less?
- Could the aluminum foil be replaced with something like paper? Would your electroscope still detect charges?

WORKFORCE CONNECTION

Electrostatic discharge engineers are scientists that focus on minimizing or eliminating electrostatic discharge. Their jobs require them to understand how the build up and discharge of electrons can impact sensitive electronics. For example, eliminating sparks created by static electricity is critical for the safety of astronauts working on space equipment. Even the slightest spark of electricity could ignite catastrophic fires when working in space.



Drawing up a Plan

Your town is getting a new library! The **facade** (front-facing side) of the library will be built according to the following dimensions. It will be 30 feet high and 60 feet wide. In the middle, there will be a set of double doors, which will be 8 feet tall and 6 feet wide. Four feet away from each door will be a window, measuring 20 feet tall and 15 feet wide. These windows will each be 3 feet up from the ground. Finally, the facade will feature two vertical columns, measuring 2 feet wide and 30 feet tall. The columns will be three feet from each end of the facade.

It's up to you to create a drawing of the facade. To make the plan fit on paper, you will have to scale it down.

The first step is to convert feet to inches.

Facade

Height: 30 feet = _____ inches

Width: 60 feet = _____ inches

Key

1 foot = 12 inches

Doors

Height: 8 feet = _____ inches

Width: 6 feet = _____ inches

Windows

Height: 20 feet = _____ inches

Width: 15 feet = _____ inches

Distance from door: 4 feet = _____ inches

Distance from ground: 3 feet = _____ inches

Columns

Height: 30 feet = _____ inches

Width: 2 feet = _____ inches

Distance from end: 3 feet = _____ inches



Revised with the permission of WGBH Educational Foundation ('WGBH') and/or Public Broadcasting Service ('PBS') (or other copyright holder indicated on the page). WGBH and/or PBS (or other indicated copyright holder) is not responsible for the content or accuracy of the revision.





The next step is to scale down those numbers! The scale we will use is $1/24$. That means that our scaled drawing will be 24 times smaller than the building. We will need to use division to figure out the scaled measurements of our drawing. Use the structure below to help you.

Facade

Height: _____ inches \div 24 = _____ inches

Width: _____ inches \div 24 = _____ inches

Doors

Height: _____ inches \div 24 = _____ inches

Width: _____ inches \div 24 = _____ inches

Windows

Height: _____ inches \div 24 = _____ inches

Width: _____ inches \div 24 = _____ inches

Distance from door: _____ inches \div 24 = _____ inches

Distance from ground: _____ inches \div 24 = _____ inches

Columns

Height: _____ inches \div 24 = _____ inches

Width: _____ inches \div 24 = _____ inches

Distance from end: _____ inches \div 24 = _____ inches

Now, it's time to draw! You will need a yardstick, a ruler, a pencil, and a large sheet of paper. Use the numbers you just found to create your scaled drawing of the library's facade. Notice that there is no description of the roof. Draw your own!



Acting Out Structures



COLUMN

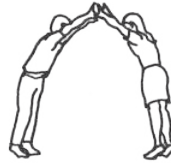

ARCH



COLUMN AND BEAM



DOME



TENSION



CANTILEVER



LOAD AND SUPPORT



VAULT / TUNNEL



COMPRESSION

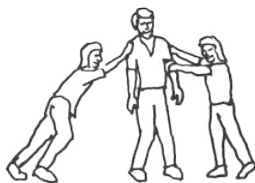

FLYING BUTTRESSES

How does your house stay standing? Architects use structures like columns, beams, and arches to make buildings strong and be sure they last for many years. Grab a grown-up or a friend and try to make columns, beams, and arches with your body!



Career Comics 1 Career Video: _____

Scan the QR code to visit the Career Girls website and find a career video that interests you. Then ask yourself: *What is this job like?* Create a comic starring you in this career. At the top, fill in the career and sign your name. Use words and pictures to tell what happens on the job!

I Want to Be _____ By _____

<p>If you like _____ and _____, you might like to be _____. (career)</p>	<p>How do you get ready for this career?</p> <p>You can start by _____ and _____.</p> <p>_____</p> <p>_____</p> <p>_____.</p>
<p>You'll need some skills, too.</p> <p>Like these:</p> <ol style="list-style-type: none">1.2.3.	<p>What else can you do to prepare?</p> <p>_____</p> <p>_____</p> <p>_____</p>

WEEK 8: SHOOT FOR THE STARS



Complete activities and play BINGO!

Scan the QR code or visit [Michiganlearning.org/summer](https://michiganlearning.org/summer) to see video lessons for this week's activities. Use the boxes below to check off activities as you complete them. See if you can get a BINGO!



Watch Read, Write, ROAR!	Complete Page 75 Activity	Look for the moon during the day	Read a story about space	Complete Page 82 Activity
Create a galaxy picture with paint or chalk	Build a cozy spot and relax there	Watch Wimee's World	Take a night walk and look at the sky	Create a new game and play it
Explore a place you've never been	Complete Page 76-77 Activity	Free Space	Find a bright star at night	Invent something that solves a problem
Complete Page 80-81 Activity	Watch Math Might	Draw how the sky changes colors at sunset	Complete Page 78 Activity	Make a constellation with dots or stickers
Build a rocket from household items	Complete Page 79 Activity	Learn one fact about space	Watch PBS KIDS	Do 30 astronaut jumps

DESCRIPTIVE WRITING



ACTIVITY GUIDE

SCAN TO WATCH LESSON



EPISODE 104 - MICHIGAN'S TASTY TREATS

We used the famous (and delicious!) Michigan pasty to help us learn a bit of history and see a model of how to write descriptively about a favorite food.



Complete the chart below with sensory words to describe *your* favorite meal. What do you see, taste, hear, smell, and touch while eating it? Then, write a few descriptive sentences about your favorite meal including sensory details from the chart to make your writing coming alive!



See



Taste



Hear



Smell



Touch

My Favorite Meal

DIY Hovercraft



FUN FACT

Lee-on-the-Solent in England is where you can find the Hovercraft Museum which holds the world's largest collection of hovercraft designs, including some of the earliest and largest hovercrafts ever created!

FRICITION

Friction is the resistance that one surface or object encounters when moving over another surface or object. Different types of materials create varying amounts of friction. Friction can be found in our everyday lives and allows us to stand without falling, drive our cars safely down the road, and allows us to even grip a racket when playing tennis.

MATERIALS

- Blank CD
- Balloons
- Glue gun
- Bottle lid (push-up type)
- Adult helper



DIFFICULTY



Why are friction jokes hard to tell at school?

**Answer on the next page*

VISIT
DIYSCIENTIME.ORG
FOR MORE SCIENCE FUN!



Copyright Alabama Public Television and Mister C, LLC 2021

DIY Hovercraft

EXPERIMENT

Step 1: Gather materials.

Step 2: Use glue to fasten the bottle cap directly over the center hole of the CD. Be sure it is sealed completely to prevent air from leaking.

Step 3: Blow up and connect a balloon to the top of the closed bottle cap.

Step 4: Open the bottle cap, allowing the air from inside the balloon to escape and observe how the hovercraft behaves on a flat surface.

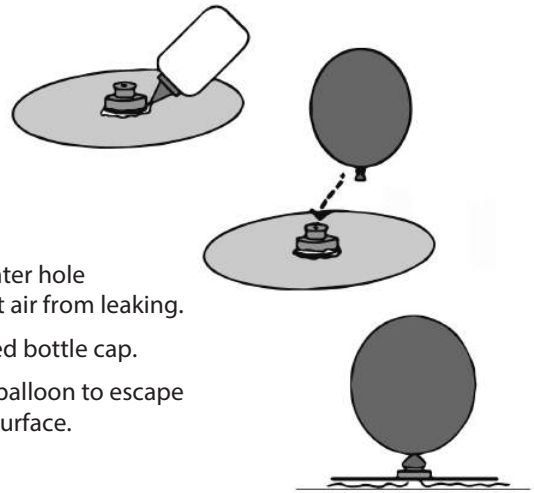

*Joke Answer -
Most teachers won't let them slide!

WHY IT WORKS

Hovercrafts work by using air to lift the craft off of the surface. As the balloon deflates, the air is pushed out through the bottom of the CD. Because of the weight, shape and texture of the CD, a thin layer of air is formed between the CD and the smooth table top surface. This layer of air reduces the friction between the CD and the surface allowing the CD to move easily and hover over the table.

EXTEND YOUR LEARNING

- What would happen if you used a different shaped balloon?
- Will it work with a heavy plastic plate, or cardboard instead of the CD?
- How far can you get your hovercraft to go? What adjustments can be made to make it move faster?
- Can your hovercraft glide across any other surfaces? Carpet? Tile? Cement?
- How much weight can your hovercraft carry?

WORKFORCE CONNECTION

Fire-rescue workers use amphibious hovercraft to rescue people in flooded, muddy or icy areas. The hovercraft can easily go up to people's homes to rescue them right at their front door and works much better than a helicopter for this purpose. Fire and rescue workers also need to understand how to operate and maneuver the craft which means part of their job is to practice these rescue scenarios in the event a real situation arises.



Show what you know!

Math Time: Equivalent Fractions

Directions: Shade each circle to show that both fractions are equivalent.

$$\frac{2}{3} = \frac{6}{9}$$
$$\frac{2}{10} = \frac{1}{5}$$
$$\frac{1}{2} = \frac{4}{8}$$
$$\frac{1}{6} = \frac{2}{12}$$
$$\frac{2}{4} = \frac{1}{2}$$
$$\frac{2}{3} = \frac{8}{12}$$

Revised with the permission of WGBH Educational Foundation ('WGBH') and/or Public Broadcasting Service ('PBS') (or other copyright holder indicated on the page). WGBH and/or PBS (or other indicated copyright holder) is not responsible for the content or accuracy of the revision.



Why Consider AI Careers

The video "[Why Consider AI Careers](#)" teaches you about the role of AI in our everyday lives and the importance of encouraging women and girls to consider AI as a career possibility. AI careers work directly with computers and sometimes with different computer languages.

Try This!

One of the basic building blocks that computers use to send and receive information is called binary code. Binary code is a code with only two symbols. First, decode the message below using binary code. Then, try using binary code to send a short message to a friend!

Creating Secret Messages in Binary Code

A	00001	J	01010	S	10011
B	00010	K	01011	T	10100
C	00011	L	01100	U	10101
D	00100	M	01101	V	10110
E	00101	N	01110	W	10111
F	00110	O	01111	X	11000
G	00111	P	10000	Y	11001
H	01000	Q	10001	Z	11010
I	01001	R	10010		

DECODE THIS: 01000 00101 01100 01100 01111 _____

Now, try writing a short message to a friend:

A =     

The 0s and 1s of this binary code aren't the only way to make a binary code. Binary just means that there must be two options. Anything that can exist in two states or forms can be used. For example, you could replace the 0s with a heads-up penny and the 1s with a tails-up penny. What other items could you use to make a binary code?

A NASA/DESIGN SQUAD CHALLENGE

ROVING ON THE MOON

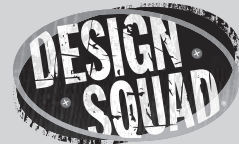
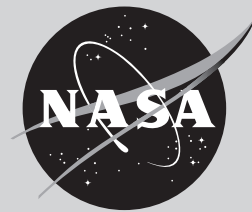

as built on TV

Can you imagine driving an all-terrain vehicle (ATV) on the moon? NASA can. It's building a fleet of ATVs (called rovers). Some can be driven by astronauts. Others are remote-controlled. All of them can handle the moon's dusty, rugged terrain. Talk about off-road adventure!

WE CHALLENGE YOU TO...

...design and build a rubber band-powered rover that can scramble across the floor.

BUILD

- 1. First, you have to make the body.** Fold the cardboard into thirds. Each part will be about 2 inches (5 cm) across. Fold along (not across) the corrugation (the tubes inside a piece of cardboard).
- 2. Then, make the front wheels.** On the two 5-inch (13-cm) cardboard squares, draw diagonal lines from corner to corner. Poke a small hole in the center (that's where the lines cross). On the body, poke one hole close to the end of each side for the axle. Make sure the holes are directly across from each other and are big enough for the pencil to spin freely.
- 3. Now attach the front wheels.** Slide the pencil through the body's axle holes. Push a wheel onto each end. Secure with tape.
- 4. Next, make the rear wheels.** Tape the straw under the back end of the rover. Slip a candy onto each end. Bend and tape the axle to stop the candies from coming off.
- 5. Finally, attach the rubber band.** Loop one end around the pencil. Cut small slits into the back end of the body. Slide the free end of the rubber bands into the slits.

MATERIALS (per rover)

- corrugated cardboard body (6-inch/15-cm square)
- 2 corrugated cardboard wheels (5-inch/13-cm square)
- 1 sharpened round pencil
- 2 rubber bands
- ruler
- tape
- 2 round candies (the hard, white, mint ones with a hole in the middle)
- 1 plastic drinking straw
- scissors

TEST, EVALUATE, AND REDESIGN

Test your rover. Wind up the wheels, set the rover down, and let it go. Did everything work? Can you make your rover go farther? Engineers improve their designs by testing them. This is called the design process. Try redesigning the wheel setup or rubber band system. For example, if:

- **the wheels don't turn freely**—
Check that the pencil turns freely in the holes. Also, make sure the wheels are firmly attached and are parallel to the sides.

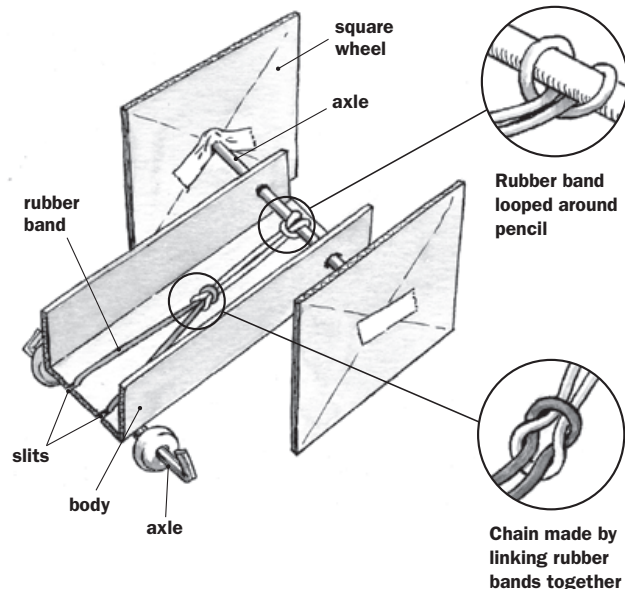

- **the rover doesn't go far**—Wind up the wheels more. Try wheels of different sizes or shapes. Or, add another rubber band or use a rubber-band chain.
- **the wheels spin out**—Add weight above the square wheels; put more wheels on the pencil; use bigger wheels; or cut open a rubber band and use only a single strand of elastic.
- **the rover won't travel in a straight line**—Check that the pencil is straight and the front wheels are the same size.



Check out NASA's moon missions at moon.msfc.nasa.gov.

CUSTOM WHEELS

The moon doesn't have an atmosphere—there's no air there! So air-filled tires like the ones on a bike or car would explode—the air inside would push through the tire to escape into outer space (where there's no air to push back against the walls of the tire). Imagine you're a NASA engineer who has to design a tire that:

- works in space, where there's no atmosphere
- withstands extreme hot and cold temperatures—on the moon, they range from roughly 250° to -250° Fahrenheit (121° to -157° Celsius)
- weighs 12 pounds (5.5 kg), which is half the weight of an average car tire
- won't get clogged with the fine dust that covers the moon

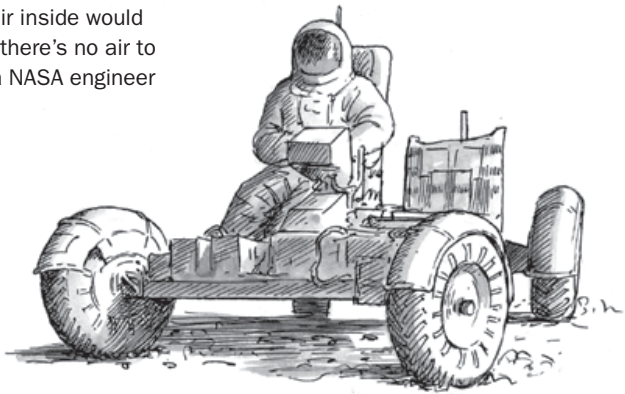

Despite these challenges, engineers designed a tire that worked perfectly when it was used on the moon. It's made of thin bands of springy metal. That helps it be lightweight, have good traction, and work at any temperature the moon can throw at it. Plus, it flexes when it hits a rock, and it doesn't need to be pumped up. Dependability is important. There's no roadside service when you're on the moon, 250,000 miles (400,000 km) from home.

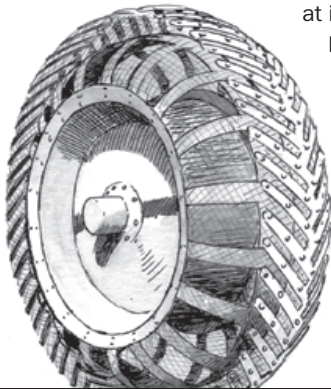

RIDE IN "STYLE"?

A rover may not be the hottest-looking vehicle around, but with a price tag of over ten million dollars, it's one of the most expensive. And it sure is convenient to bring along. Rovers can be folded and stored in a landing module the size of a small room. Look at the picture of the rover. Which features are also found on cars designed for use on Earth?

Answers: Chassis, wheels, fenders, motor, seats, seat belts, antenna, battery, camera (some cars), and steering controls.

The farthest trip anyone has ever taken on the moon with a rover is 2.8 miles (4.5 km).

Watch **DESIGN SQUAD** on PBS or online at pbs.org/designsquad.



Major funding for *Design Squad* provided by



Additional funding for *Design Squad* provided by



Design Squad is produced by WGBH Boston. *Design Squad*, AS BUILT ON TV, and associated logos are trademarks of WGBH. All rights reserved. This NASA/*Design Squad* challenge was produced through the support of the National Aeronautics and Space Administration (NASA).



For more information about NASA missions and educational programs, visit nasa.gov.

DON'T HATE! APPRECIATE! LET'S WRITE AN ODE!



ACTIVITY GUIDE

SCAN TO WATCH LESSON



EPISODE 104: TASTY MICHIGAN TREATS

Let's Celebrate What We Love

An ode is an ancient form of poetry that offers praise for an emotion, an activity, a person, place or thing, or an idea.

Write an ode where you choose something in your local surroundings or community to praise. Directly address the object of your affections with a second-person pronoun (you). Use hyperbole. Try to write at least 10 lines!

An Ode to _____

KEEP LEARNING. KEEP PLAYING. ALL SUMMER LONG.

We've got even more videos, activity sheets, and hands-on science experiments through the Michigan Learning Channel to keep the fun going all summer long!

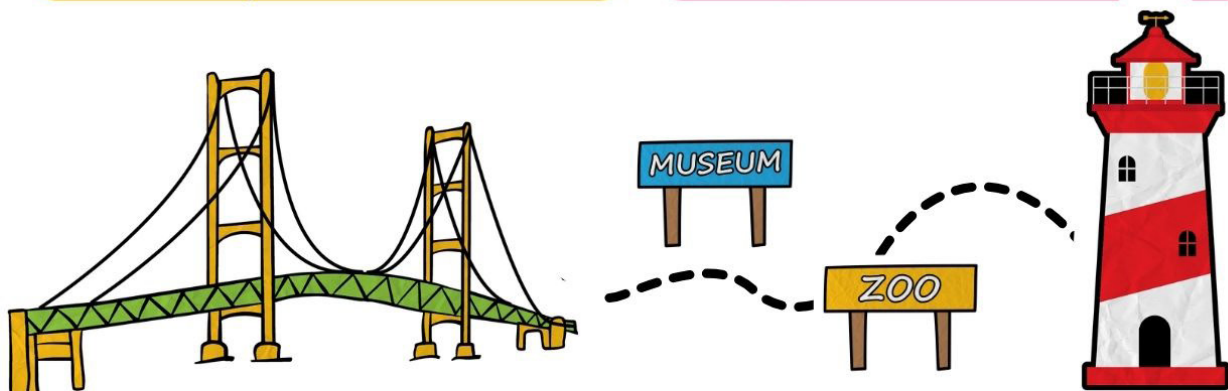

Michigan Learning Channel is powered by your local PBS stations.



This work was made possible by the generous support of:



ALBERT & JANICE MEISTER FAMILY FOUNDATION

And by viewers like you.

